

# TOSHIBA

Variable Speed Drive

# TOSVERT™ VF-S15



# Features

## 1. Easy setting, Simple operation

### Easy setting, simple operation with the large dial

Just turn and push the large setting dial to browse and select the right parameter. The reference frequency can be also set by the large setting dial.



### Parameter can be set without power supply to the inverter

Using the optional parameter writer, you can read/write/retain/set parameters. It is useful in case of incorporate numbers of inverters to the machine.



### Showing most frequently used parameter in EASY mode.

EASY key allows you switch between EASY mode and Standard mode.  
 EASY mode: Scrolls through a list of most frequently used parameter.(32 parameters in maximum.)  
 Standard mode: Show all existing parameters.

## Contents

Features	p.1
Useful Function and specification	p.3
Useful Function for wide range applications	p.5
Functions	p.7
Panel and operation procedure	p.8
Dimensions and weight	p.10
Specifications	p.11
Connection diagram	p.13
Peripheral devices	p.15
To users of our inverters	p.20

## 2. Eco Design

### Long lifetime

Long life main-circuit capacitor is used to achieve 10 years lifetime design.  
*\*Average ambient temperature 40°C, load factor 80% or less, 24-hour and 365 days operation.*

### Harmonize with environment

- Compliance with the European RoHS Directive.
- Built-in noise filters to suppress electromagnetic noise.
  - 1-Phase 240V models and 3-Phase 500V models: Built-in EMC noise filter complies with the European EMC Directive.
  - 3-Phase 240V models: Built-in basic noise filter.

### Side-by-side installation

Side-by-side installation is possible for all VF-S15 models. It means that you can further save space as two or more units can be installed in close proximity next to each other.

## 3. Energy savings & Powerful operation

### Along with the motor, achieve energy savings.

- High energy saving performance PM motor can be driven normally.  
 Auto-tuning can set motor constant easily.
- Energy saving mode for induction motor.  
 Improve the energy saving effect of variable torque load such as fan and pump.



### Easy operation of high torque load.

Vector control mode generate stable, high torque power from motor startup to a desired motor operating speed. Further, if you set the starting frequency to 0.1Hz, motor can start smoothly with strength.

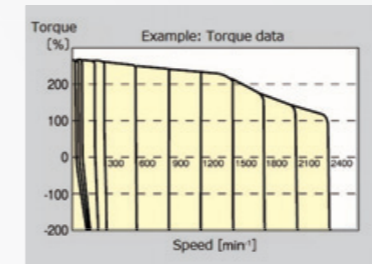

When a Toshiba standard 3-phase 400V-1.5kW motor is driven by the VFS15-4015PL-W after parameters are set.

## 4. Applicability

### Auto-tuning can setup motor constant easily.

With vector control mode and PM motor control mode, auto-tuning function leads you easy access to motor constant setup and fully use of all the advantages of motor.

### Motor information is required for the auto-tuning:

- Motor rated capacity (kW)
- Motor rated current (A)
- Motor rated speed (min<sup>-1</sup>)
- Motor rated Voltage (V) (In case of PM: Induced voltage(RMS between the line))

*\*Please find the information on the motor's name plate.*

### Easily adjust the lifting application by learning function.

A learning function for setting and storing to memory required parameters while performing actual operations is also provided to facilitate adjustments. Every model is built-in braking resistor drive circuit.

## 5. Expandability of the system

### Built-in RS485 is equipped as standard

Modbus-RTU protocol /TOSHIBA protocol is complied. Communication speed: Maximum 38.4kpbs

### Variety of communication options

CC-Link, PROFIBUS-DP, PROFINET, DeviceNet™, EtherNet/IP™, EtherCAT®, CANopen®

Voltage class (Input/Output)	Applicable motor(kW)									
	0.2	0.4	0.75	1.5	2.2	4.0	5.5	7.5	11	15
3φ240V/3φ240V	—	✓	✓	✓	✓	✓	✓	✓	✓	✓
1φ240V/3φ240V	✓	✓	✓	✓	✓	—	—	—	—	—
3φ500V/3φ500V	—	✓	✓	✓	✓	✓	✓	✓	✓	✓



# Useful function and specification

## Simplify the system

### Panel display control

Contents of your requests, such as load condition, could be viewed on the inverter's panel. (Using the communications)



### Shows power by the pulse count

Integrated power can be output by the pulse. Even without the external wattmeter, power can be shown by the pulse count.

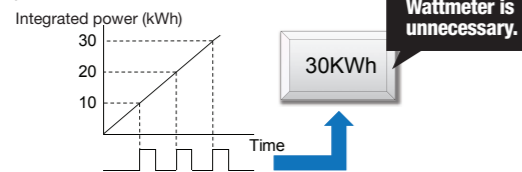

### Flexible terminals

The terminal function settings can be changed. Multiple input terminal functions can be assigned with single input terminal to simplify the external circuit.

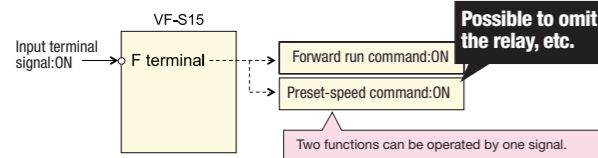

## Useful for OEM

### Parameters can be set easily

#### •Application easy setting

6 parameters for particular usages are available. Parameters match to your machine can be displayed and setup easily by using the application easy setting.

**AUA Application easy setting**

- 1: Initial easy setting
- 2: Conveyor
- 3: Material handling
- 4: Hoisting
- 5: Fan
- 6: Pump
- 7: Compressor

#### •Protection of the setting parameters.

VF-S15 provides protection for the setting parameters. Four-digit password is required to reinforce the security. VF-S15 can save and restore a set of parameters.

#### •Setting from extension parameter writer.

#### •Setting and management on a PC: PCM002Z. (Refer to Page 4)

### Easy wiring

#### •Detachable control terminal board

Remove the terminal board to wiring efficiently.

## Useful to building the system

### Control power supply backup

Control power supply is supplied from the inverter's main circuit and also supplied by another input. It can maintain the output signal and trip indication, when the main circuit power supply circuit is also turned off due to inverter trip.

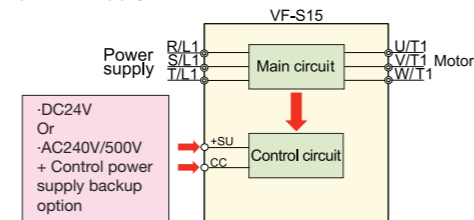

### Continuously adjustment from analog input

Can be adjusted continuously by analog input, the value to be set by the parameter.

#### < Adjustment parameters >

- Acceleration/Deceleration time
- Upper limit frequency
- Torque boost value
- Motor electronic-thermal protection level etc.

\*For processing by the internal, parameter settings are not changed

## International Standards

### •Compliant with major international standards



Compatible with the World's Main Standards (EC Directive(CE marking),UL, CSA)

#### •Sink/Source control logic

It can be configured for both sink logic and source logic.

#### •Built-in EMC filter

1-phase 240V and 3-phase 500V model have built-in noise filter complied with the European EMC Directive.

#### •Wide variety of applied conditions

Power supply — 240V class model is for 200~240V, 500V class model is for 380V~500V. It can correspond to a wide range of power supply

Ambient temperature — It can be used maximum ambient temperature of 60°C \*1

Altitude — Maximum altitude 3000 meter\*1

\*1 The maximum output current may be limited depend on the operating conditions

## Easy maintenance

#### •Monitor number of starting

Displaying number of starting and output the alarm signal are helpful for maintenance.

#### •Details on history trip records

Output current, input voltage etc, a monitor to identify the cause of the problem and help to find countermeasures. VF-S15 can keep memories of the last eight trips even after resetting.

#### •Tracing function (Refer to page 4)

## Safety function

Safety function prevents a disaster caused by a complex Machine, not only operator but also machine design regards to safety precaution. It is insulating the output reliability in the event of an emergency. And it can simply the system and reduce the wiring and external devices cost.

### Compliant with safety standards:

Possible to disconnect the output corresponding to the safety standard.

- EN954-1 Category 3
- IEC61800-5-2/IEC61508 SIL2
- IEC62061 SIL2 CL
- ISO13849-1 Category 3 PL "d"
- IEC60204-1 Category stop 0, 1

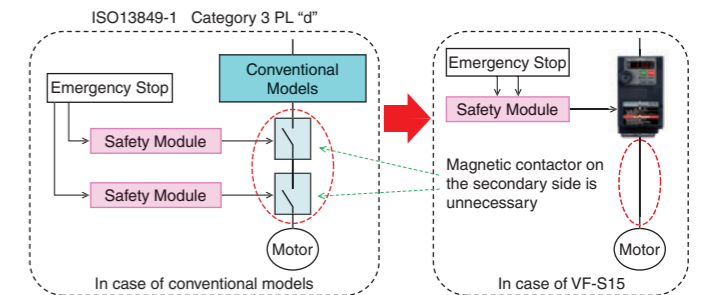

## PM motor drive technology

The VF-S15 can drive Interior Permanent Magnetic Motor(IPM) and Surface Permanent Magnetic Motor(SPM) for high efficiency, high torque energy saving, downsizing and lightening.



## My function

My function enhances programming capability to inverter's input/output signals to respond to customer needs without external relays or a PC in some cases. Easy programming tool (PCL001Z) is available.

#### •Easy programming(PCL001Z)

My function parameter can be set easily by the PCL001Z



## Dual rating (CT/VT)

The VF-S15 can be used the constant torque and variable torque applications by dual rating operation. For example, if variable application (fan and pump) required 15kW drives, it can be operated by 11kW rated of VF-S15.

### Constant torque application

The torque value of constant torque application require the high torque level of different motor speed for conveyors, Machine tools, Food machine and Elevator.

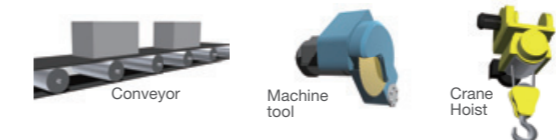

### Variable torque application

The torque value of variable torque application such as Fan, Pump and HVAC require low torque unit to operating speed.



Caution: VT mode isn't compliant with UL and CSA standard.

## Communication

#### •Built-in

RS-485 communications: Modbus-RTU protocol/TOSHIBA protocol.

#### •Network options

- CC-Link
- PROFIBUS-DP
- PROFINET
- DeviceNet™
- EtherNet/IP™-Modbus TCP
- EtherCAT®
- CANopen®

\*Registered trademark  
CC-Link is Mitsubishi Electric Corporation DeviceNet is ODVA(Open DeviceNet Vendor Association) EtherNet/IP is ControlNet International, Ltd EtherCAT is Beckhoff AutomationGmbH CANopen is CAN in Automation.

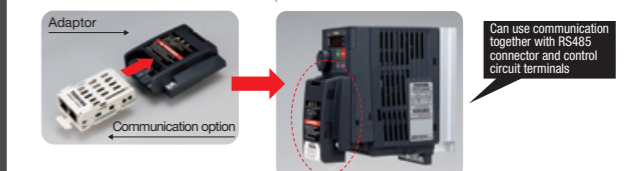

#### Operation-Management on a PC (Free software available)

##### •Edit and monitor(PCM002Z)

The PCM002Z communication software allows you to edit, monitor, and trace parameter data on a PC, enabling easier data management from inverter startup through to maintenance.

##### •Data storage of the protection operation: Tracing function(PCT001Z)

Memorize and read out the data collected at the time of tripping or triggering.

##### •Remote control

Using the EtherNet option, it can be remote controlled from PC.

# Useful function for wide range applications

VF-S15 for machinery and facilities in various industrial sector and application



Machinery and Facilities												
Material handling (Horizontal)	Material handling (Vertical)		Fans & Pumps	Food processing machinery	Packaging machinery	Daily-life-related machinery	Medical equipment	Textile line	Chemical machinery	Printing machinery	Machine tools Processing machinery	Semiconductor facility equipment
Conveyor	Crane Hoist		Pumps Fans/blowers Compressor	Food machines	Band tighteners	Car washing machine Commercial ironing boards	X-ray machines Treadmill	Textile machines	Mixers	Printing presses	Machine tools	
✓: ideal ✓✓: applicable	• Automatic vertical storage units			• Food machines • Food slicers • Bakery equipment • Tea-making machines • Driers	• Wrapping machines • Trimming machines • Packing machines	• Raw garbage disposal • Shredder • Shutter	• Nursing beds • Water beds • Massage machines	• Weaving machines • Knitting machines • Dyeing/finishing machines • Sewing machines	• Painting machines	• Binding machines	• Cutters • Welding machines • Grinding machines • Woodworking machinery	• Semiconductor production equipment • LCD production equipment

Function & Advantage												
Easy setting Simple operation	External parameter writer	Parameter can be set without power supply.	✓			✓✓	✓✓	✓✓	✓✓	✓	✓	✓
	Easy setting mode	Show most frequently used parameters in EASY mode.	✓			✓✓	✓			✓	✓	✓
	Application easy setting	6 parameters for particular usages are available.	✓✓	✓✓		✓✓						
	Password lock	A four-digit password is required to change the parameters if necessary.	✓	✓			✓✓	✓✓	✓	✓	✓	✓✓
	Side-by-side installation	Two or more inverter units can be installed in close proximity next to each other	✓				✓✓	✓	✓✓		✓	
	Ambient temperature: 60°C	Maximum ambient temperature: 60°C					✓	✓✓	✓	✓		
Eco Design	Long lifetime	Designed for 10 years lifetime design	✓			✓✓				✓		
	Built-in noise filter	Built-in EMC noise filter comply with European EMC Directive				✓	✓	✓	✓✓	✓✓		✓✓
	Random mode	Improves hearing impression by changing the pattern of the low carrier frequency					✓		✓✓	✓✓		
Energy savings & Powerful operation	PM motor	PM motor can drive for high efficiency, downsizing and lightening.(For variable torque)				✓✓						
	Energy saving mode	Energy can be saved in all speed areas by detecting load current and following the optimum current that fits the load				✓✓	✓	✓	✓	✓		
	High torque drive	VF-S15 supports sensorless vector control mode to generate stable, high-torque power from motor startup to a predefined, desired motor operating speed.	✓✓	✓✓			✓	✓	✓	✓	✓✓	✓
Applicability	Auto-tuning	This auto-tuning function allows you to set the motor constant easily, which needs to be set when operating in vector control or PM motor drive	✓✓	✓✓		✓✓	✓	✓	✓	✓	✓✓	✓✓
	Learning function	Setting and storing to memory required parameter while performing actual operation is also provided to facilitate adjustments	✓	✓✓								
	Override function	Preventing loads from concentrating at a specific motor because of a load imbalance when multiple inverters are used to operate one machine	✓				✓		✓	✓		✓
	ACC/DEC pattern (S-pattern) function	To minimize the shocks caused in starting and stopping and change the ACC/DEC rate according to the machine characteristics and its applications.	✓✓				✓		✓	✓		
	DC brake function	A large braking torque can be obtained by applying a direct current to the motor	✓✓	✓			✓		✓	✓		
	Dwell function	Suspends acceleration and deceleration to match the timing of brake	✓				✓	✓	✓	✓		✓✓
	Auto-restart control	Detects the rotating speed rotational direction of the motor during coasting at the event of momentary power failure, and then after power has been restored, restarts the motor smoothly	✓✓				✓✓			✓		
	PID control	To use temperature, pressure, flow and motion control					✓✓	✓		✓		
	Sleep function	Additional energy saving can be realized by stopping at lower limit setting					✓✓	✓		✓		
	Bumpless function	When switching from Remote mode to Local mode, the status of start and stop, and operating frequency at Remote mode move to Local mode.					✓✓		✓	✓		
Expandability of the system	Network communication	Built-in RS485. Can be connected to the common industrial communication	✓	✓		✓✓	✓✓	✓✓	✓✓	✓✓	✓	✓
	Panel display control (Using the communication)	Contents of your requests, such as condition, can be viewed on the inverter's panel	✓			✓	✓✓	✓✓	✓	✓✓		
	Parameter adjustment by Analog input	Parameters adjustable from external analog input	✓✓				✓		✓	✓✓	✓	
	Control power supply can supplied from another input	Control power supply is supplied from the inverter's main circuit and also supplied by another input. It can maintain the output signal and trip indication, when the inverter become trip.	✓✓	✓✓			✓✓			✓✓	✓✓	✓✓
Other	For more details of each functions, please confirm with Toshiba representative offices or Toshiba authorized distributors in your country.					Torque limit	Low voltage operation function, Shock monitoring function	Fire control enables forced operation				Traverse function Synchronized deceleration

# Panel and operation procedure

# TOSVERT VF-S15



## Power on (setup parameter)

1. When power on the inverter for the first time, **SEt** is blinking.



2. Select an area code by the setting dial.

**JP/USA/RS/IEU**



3. Press the center of the setting dial to confirm your change. When **in It** is displayed and then **0.0**, you finish setting setup parameter.



## Values set by each setup parameter

Title	Function	EU (Mainly in Europe)	USA (Mainly in North America)	RS/IA (Mainly in Asia, Oceania) Note 1)	JP (Mainly in Japan)
U1/U1/F170/ F204/F213/ F219/F330/ F367/F814	Frequency	50.0(Hz)	60.0(Hz)	50.0(Hz)	60.0(Hz)
U14/ F111	Base frequency voltage 1, 2	240V class	230(V)	230(V)	200(V)
		500V class	400(V)	460(V)	400(V)
Pt	V/F control mode selection	0	0	0	2
F307	Supply voltage correction (output voltage limitation)	2	2	2	3
F319	Regenerative over-excitation upper limit	120	120	120	140
F417	Motor rated speed	1410(min <sup>-1</sup> )	1710(min <sup>-1</sup> )	1410(min <sup>-1</sup> )	1710(min <sup>-1</sup> )

Note 1) Excluding Japan

## Monitor display

The LEDs on the operation panel display the following symbols indicate operations and parameters.

### LED (number)

0	1	2	3	4	5	6	7	8	9	-
0	1	2	3	4	5	6	7	8	9	-

### LED (alphabet)

Aa	Bb	C	c	Dd	Ee	Ff	Gg	H	h	I	i	Jj	Kk	Ll	Mm	Nn	O	o	Pp	Qq	Rr	Ss	Tt	Uu	Vv	Ww	Xx	Yy	Zz
A	b	C	c	d	E	F	G	H	h	I	i	J	K	L	M	n	O	o	P	q	r	S	t	U	v	W	X	Y	Z

## ACC/DEC pattern (S-pattern) function

To minimize the shocks caused in starting and stopping and change the ACC/DEC rate according to the machine characteristics and its applications.

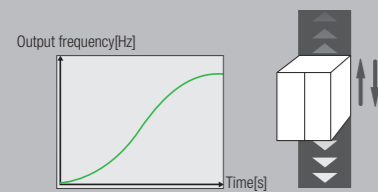

## Override function

Adjust reference frequencies by means of external input.

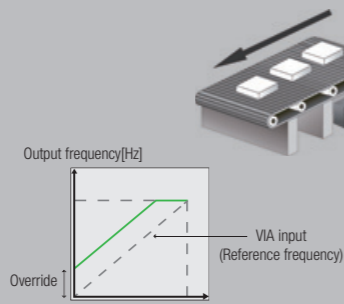

## Bumpless function

When switching from Remote mode to Local mode, the status of start and stop, and operating frequency at Remote mode move to Local mode.

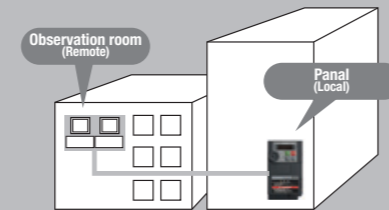

## Learning function

Setting and storing to memory required parameters while performing actual operation is also provided to facilitate adjustments.



# Functions

## Sleep function

If operation at the lower-limit frequency is carried out for the setting time, the inverter will automatically decelerate the motor stop for the purpose of energy-saving.

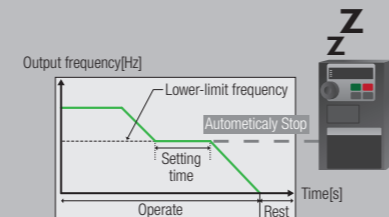

## Drooping function

Preventing loads from concentrating at a specific motor because of a load imbalance when multiple inverters are used to operate one machine.

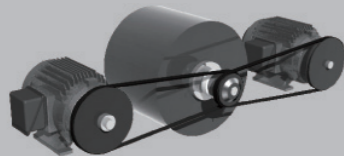

## PID control function

Process control including keeping airflow, pressure, and the amount of flow constant, can be exercised using feedback signals (4 to 20mA, 0 to 10V) from a detector.

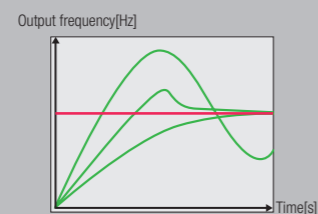

## Auto-restart control function

Detects the rotating speed rotational direction of the motor during coasting at the event of momentary power failure, and then after power has been restored, restarts the motor smoothly.

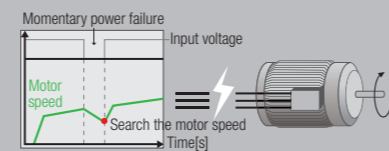

## Auto-tuning

This auto-tuning function allows you to set the motor constant easily, which needs to be set when operating in vector control or PM motor drive.



## DC brake function

A large braking torque can be obtained by applying a direct current to the motor.

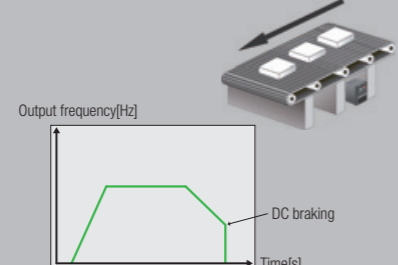

## Dwell function

It prevents the occurrence of overcurrent at starting and slippage of stopping by fixing the timing with brake.

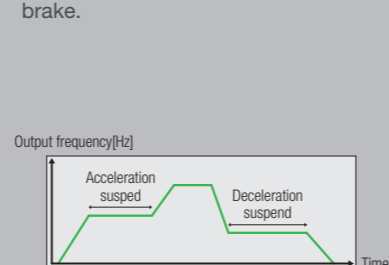

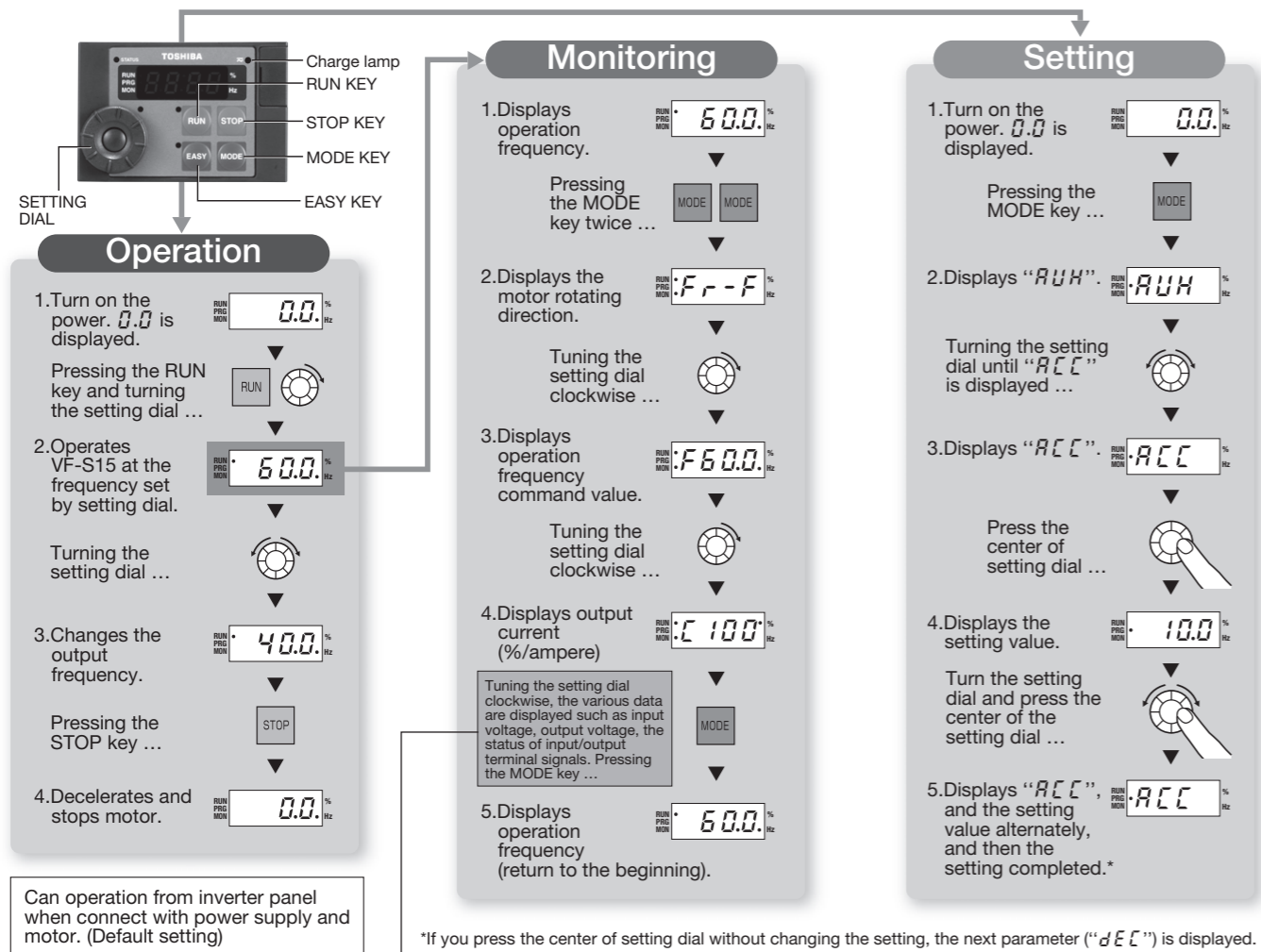

Item displayed	Panel operated	LED display	Description	Item displayed	Panel operated	LED display	Description
Output frequency *		60.0	The output frequency is displayed (Operation at 60Hz). (When standard monitor display selection F710 is set at 0 [output frequency])	CPU1 version		v101	The version of the CPU1 is displayed.
Parameter setting mode	MODE	RUH	The first basic parameter "RUH" (history function) is displayed.	CPU2 version		vc01	The version of the CPU2 is displayed.
Direction of rotation	MODE	F--F	The direction of rotation is displayed. (F--F: forward run, F--r: reverse run)	Inverter rated current		R33.0	The inverter rated current (A) is displayed.
Frequency command value *		F60.0	The frequency command value (Hz/free unit) is displayed. (In case of F711=2)	Overload and region setting		L-EU	The inverter overload characteristic and region setting is displayed.
Output current *		L80	The inverter output current (load current) (%/A) is displayed. (In case of F712=1)	Past trip 1		0P2<math>\infty</math>1	Past trip 1 (displayed alternately)
Input voltage *		y100	The inverter Input voltage (DC detection) (%/V) is displayed. (In case of F713=3)	...			
Output voltage *		P100	The inverter output voltage (%/V) is displayed. (In case of F714=4)	Past trip 8		nEr<math>\infty</math>B	Past trip 8 (displayed alternately)
Input power *		h12.3	The inverter input power (kW) is displayed. (In case of F715=5)	Communication Status	5L	..	The status of signal transmission and reception of communication are displayed in bits.  receiving or transmitting : 1 not receiving or not transmitting: ,
Output power *		H11.8	The inverter output power (kW) is displayed. (In case of F716=6)	Parts replacement alarm information	n	.....	The ON/OFF status of each of the cooling fan, circuit board capacitor, main circuit capacitor of parts replacement alarm, cumulative operation time or number of starting are displayed in bits.  Number of starting Cumulative operation time Cooling fan Control circuit board capacitor Main circuit capacitor
Inverter load factor *		L70	The inverter load factor (%) is displayed. (In case of F717=27)	Cumulative operation time		t10.1	The cumulative operation time is displayed. (0.10=10 hours, 1.00=100 hours)
Output frequency *		o60.0	The output frequency (Hz/free unit) is displayed. (In case of F718=0)	Number of starting		n34.5	Number of starting (10000 times)
Input terminal		.....	The ON/OFF status of each of the control signal input terminals (F, R, RES, S1, S2, S3, VIB, VIA) are displayed in bits.  ON: 1 OFF: ,	Default display mode	MODE	60.0	The output frequency is displayed (Operation at 60Hz).
Output terminal		0...1	The ON/OFF status of each of the control signal output terminals (RY-RC, OUT, FL) are displayed in bits.  ON: 1 OFF: ,				

\*Monitor items can be selected by setting parameters F710 to F718. (F720).

# Dimensions and weight

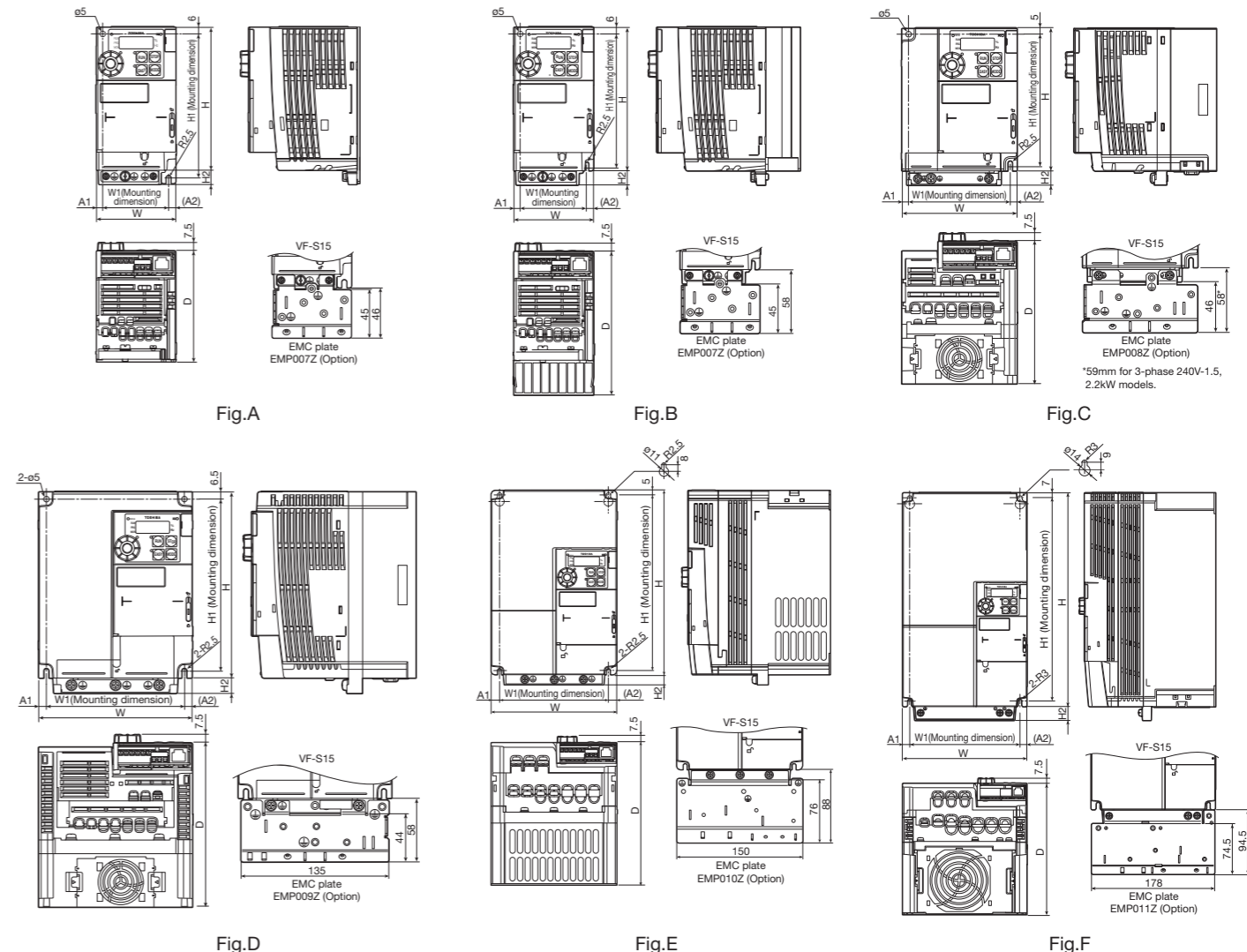

Note 1. The models shown in Fig. A, Fig. B and Fig. C are fixed at two points: in the upper left and lower right corners.  
 Note 2. The model shown in Fig. A and Fig. B are not equipped with a cooling fan.  
 Note 3. The cooling fan of 1-phase 240V-1.5, 2.2kW models and 3-phase 500V-0.4 to 1.5kW models are on the upper side of the inverter.  
 Note 4. H2 means Height of EMC plate mounting area

Voltage class	Applicable motor (kW)	Inverter type	Dimensions (mm)								Drawing	Approx. mass (kg)
			W	H	D	W1	H1	H2	A1	A2		
3-phase 240V	0.4	VFS15-2004PM-W1	72	130	120	60	121.5	13	5.5	6.5	B	0.9
	0.75	VFS15-2007PM-W1			130							1.0
	1.5	VFS15-2015PM-W1	105	170	130	93	157	14	6	6	C	1.4
	2.2	VFS15-2022PM-W1			150							1.4
	4.0	VFS15-2037PM-W1	150	220	170	130	210	12	7	7	D	2.2
	5.5	VFS15-2055PM-W1			190							3.5
	7.5	VFS15-2075PM-W1	180	310	190	160	295	20	10	10	E	3.6
11	VFS15-2110PM-W1	210			6.8							
15	VFS15-2150PM-W1	295	6.9									
1-phase 240V	0.2	VFS15S-2002PL-W1	72	130	101	60	131	13	5.5	6.5	A	0.8
	0.4	VFS15S-2004PL-W1			120							1.0
	0.75	VFS15S-2007PL-W1	105	170	135	93	157	14	6	6	B	1.1
	1.5	VFS15S-2015PL-W1			150							1.6
	2.2	VFS15S-2022PL-W1	105	220	150	121.5	12	6	6	C	1.6	
	4.0	VFS15-4004PL1-W1			190						1.2	
0.75	VFS15-4007PL1-W1	105	130	150	93	121.5	12	6	6	C	1.2	
1.5	VFS15-4015PL1-W1			190							1.3	
3-phase 500V	2.2	VFS15-4022PL1-W1	140	170	150	126	157	14	7	7	D	2.1
	4.0	VFS15-4037PL1-W1			190							2.2
	5.5	VFS15-4055PL-W1	150	220	170	130	210	12	10	10	E	3.9
	7.5	VFS15-4075PL-W1			210							4.0
	11	VFS15-4110PL-W1	180	310	190	160	295	20	10	10	F	6.4
	15	VFS15-4150PL-W1			295							6.5

# Specifications

## Standard specification

Item	Specification										
Input voltage	3-phase 240V										
Applicable motor (kW)	0.4	0.75	1.5	2.2	4.0	5.5	7.5	11	15		
Rating	Type	VFS15									
	Form	2004PM-W1	2007PM-W1	2015PM-W1	2022PM-W1	2037PM-W1	2055PM-W1	2075PM-W1	2110PM-W1	2150PM-W1	
	Capacity (kVA) Note 1)	1.3	1.8	3.0	4.2	6.7	10.5	12.6	20.6	25.1	
	Rated output current (A) Note 2)	3.3 (3.3)	4.8 (4.4)	8.0 (7.9)	11.0 (10.0)	17.5 (16.4)	27.5 (25.0)	33.0 (33.0)	54.0 (49.0)	66.0 (60.0)	
	Output voltage Note 3)	3-phase 200V to 240V									
Overload current rating	150%-60 seconds, 200%-0.5 second										
Power supply	Voltage-frequency	3-phase 200V to 240V - 50/60Hz									
	Allowable fluctuation	Voltage 170V to 264V Note 4), frequency ±5%									
	Required Power supply capacity (kVA) Note 5)	1.4	2.5	4.3	5.7	9.2	13.8	17.8	24.3	31.6	
Protective method (IEC60529)	IP20										
Cooling method	Self-cooling					Forced air-cooled					
Color	RAL7016										
Built-in filter	Basic filter										

Item	Specification														
Input voltage	1-phase 240V							3-phase 500V							
Applicable motor (kW)	0.2	0.4	0.75	1.5	2.2	0.4	0.75	1.5	2.2	4.0	5.5	7.5	11	15	
Rating	Type	VFS15S							VFS15						
	Form	2002PL-W1	2004PL-W1	2007PL-W1	2015PL-W1	2022PL-W1	4004PL1-W1	4007PL1-W1	4015PL1-W1	4022PL1-W1	4037PL1-W1	4055PL-W1	4075PL-W1	4110PL-W1	4150PL-W1
	Capacity (kVA) Note 1)	0.6	1.3	1.8	3.0	4.2	1.1	1.8	3.1	4.2	7.2	10.9	13.0	21.1	25.1
	Rated output current (A) Note 2)	1.5 (1.5)	3.3 (3.3)	4.8 (4.4)	8.0 (7.9)	11.0 (10.0)	1.5 (1.5)	2.3 (2.1)	4.1 (3.7)	5.5 (5.0)	9.5 (8.6)	14.3 (13.0)	17.0 (17.0)	27.7 (25.0)	33.0 (30.0)
	Rated output voltage Note 3)	3-phase 200V to 240V							3-phase 380V to 500V						
Overload current rating	150%-60 seconds, 200%-0.5 second							150%-60 seconds, 200% -0.5 second							
Power supply	Voltage-frequency	1-phase 200V to 240V - 50/60Hz							3-phase 380V to 500V - 50/60Hz						
	Allowable fluctuation	Voltage 170V to 264V Note 4), frequency±5%							Voltage 323V to 550V Note 4), frequency ±5%						
	Required Power supply capacity (kVA) Note 5)	0.8	1.4	2.3	4.0	5.4	1.6	2.7	4.7	6.4	10.0	15.2	19.5	26.9	34.9
Protective method (IEC60529)	IP20							IP20							
Cooling method	Self-cooling			Forced air-cooled				Forced air-cooled							
Color	RAL7016							RAL7016							
Built-in filter	EMC filter							EMC filter							

Note 1. Capacity is calculated at 220V for the 240V models, at 440V for the 500V models.  
 Note 2. Indicates rated output current setting when the PWM carrier frequency (parameter  $F_{300}$ ) is 4kHz or less. When exceeding 4kHz, the rated output current setting is indicated in the parentheses. It needs to be further reduced for PWM carrier frequencies above 12 kHz.  
 The rated output current is reduced even further for 500V models with a supply voltage of 480V or more.  
 The default setting of the PWM carrier frequency is 12kHz.  
 Note 3. Maximum output voltage is the same as the input voltage.  
 Note 4. At 180V-264V for the 240V models, at 342V-550V for the 500V models when the inverter is used continuously (load of 100%).  
 Note 5. Required power supply capacity varies with the value of the power supply side inverter impedance (including those of the input reactor and cables).

## Explanation of the type-form

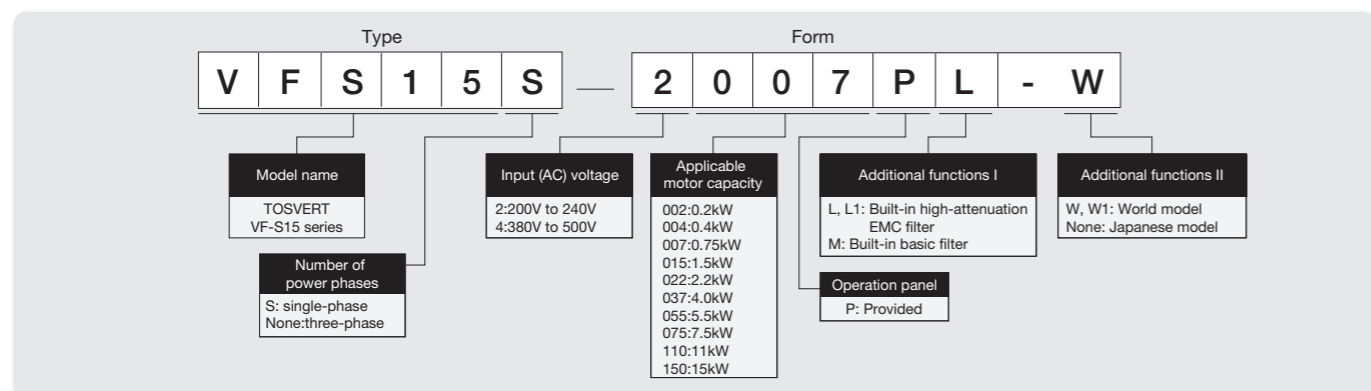

## Common specification

Item	Specification
Control system	Sinusoidal PWM control
Output frequency range	0.1 to 500.0Hz, default setting: 0.5 to 60Hz, maximum frequency: 30 to 500Hz
Minimum setting steps of frequency	Analog input : 1/1000 of the max. frequency (At 60Hz : 0.06Hz) ; VIA, VIB terminal (0-10V), VIC terminal (4-20mA) Operation panel setting : 0.01Hz (99.99Hz or less) , 0.1Hz (100.0Hz or more) Communication setting : 0.01Hz
Frequency accuracy	Analog setting: within ±0.5% of the max. frequency (25°C ±10°C) Digital setting : within ±0.01% of the max. frequency (-10 to +60°C)
Voltage/frequency characteristics	V/f constant, variable torque, automatic torque boost, vector control, automatic energy-saving, dynamic automatic energy-saving control (for fan and pump), PM motor control, V/F 5-point setting, Auto-tuning, Base frequency (20-500Hz) adjusting to 1 & 2, torque boost (0-30%) adjusting to 1 & 2, adjusting frequency at start (0.1-10Hz)
Frequency setting signal	Setting dial on the front panel, external frequency potentiometer (connectable to a potentiometer with a rated impedance of 1k-10kΩ), 0-10Vdc / -10-+10Vdc (input impedance: 30kΩ), 4-20mAdc (input impedance: 250Ω).
Terminal block base frequency	The characteristic can be set arbitrarily by two-point setting. Possible to set: analog input (VIA, VIB, VIC).
Frequency jump	Three frequencies can be set. Setting of the jump frequency and the range.
Upper- and lower-limit frequencies	Upper-limit frequency: 0.5 to max. frequency, lower-limit frequency: 0 to upper-limit frequency
PWM carrier frequency	Adjustable range of 2.0k to 16.0kHz (default: 12.0kHz).
PID control	Setting of proportional gain, integral gain, differential gain and control waiting time. Checking whether the PID set value and the feedback value agree.
Acceleration/deceleration time	Selectable from among acceleration/deceleration times 1 & 2 & 3 (0.0 to 3600 sec.). Automatic acceleration/deceleration function. S-pattern acceleration/deceleration 1 & 2 and S-pattern adjustable. Control of forced rapid deceleration and dynamic rapid deceleration.
DC braking	Braking start-up frequency: 0 to maximum frequency, braking rate: 0 to 100%, braking time: 0 to 25.5 seconds, emergency DC braking, motor shaft fixing control.
Dynamic Braking Drive Circuit	Control and drive circuit is built in the inverter with the braking resistor outside (optional).
Input terminal function (programmable)	Possible to select from among about 110 functions, such as forward/reverse run signal input, jog run signal input, operation base signal input and reset signal input, to assign to 8 input terminals. Logic selectable between sink and source.
Output terminal functions (programmable)	Possible to select from among about 150 functions, such as upper/lower limit frequency signal output, low speed detection signal output, specified speed reach signal output and failure signal output, to assign to FL relay output, open collector output terminal, and RY output terminals.
Forward/reverse run	The RUN and STOP keys on the operation panel are used to start and stop operation, respectively. Forward/reverse run possible through communication and logic inputs from the terminal block.
Jog run	Jog mode, if selected, allows jog operation from the terminal block and also from remote keypad.
Preset speed operation	Frequency references + 15-speed operation possible by changing the combination of 4 contacts on the terminal block.
Retry operation	Capable of restarting automatically after a check of the main circuit elements in case the protective function is activated. 10 times (Max.) (selectable with a parameter)
Various prohibition settings / Password setting	Possible to write-protect parameters and to prohibit the change of panel frequency settings and the use of operation panel for operation, emergency stop or resetting. Possible to write-protect parameters by setting 4 digits password and terminal input.
Regenerative power ride-through control	Possible to keep the motor running using its regenerative energy in case of a momentary power failure (default: OFF).
Auto-restart operation	In the event of a momentary power failure, the inverter reads the rotational speed of the coasting motor and outputs a frequency appropriate to the rotational speed in order to restart the motor smoothly. This function can also be used when switching to commercial power.
Light-load high-speed operation	Increases the operating efficiency of the machine by increasing the rotational speed of the motor when it is operated under light load.
Drooping function	When two or more inverters are used to operate a single load, this function prevents load from concentrating on one inverter due to unbalance.
Override function	External input signal adjustment is possible to the operation frequency command value.
Relay output signal	1c- contact output and 1a- contact output Note1) Maximum switching capacity : 250Vac-2A , 30Vdc-2A (cosφ=1: at resistive load), 250Vac-1A (cosφ=0.4) , 30Vdc-1A (L/R=7ms) Minimum permissible load : 5Vdc-100mA, 24Vdc-5mA
Protective function	Stall prevention, current limitation, over-current, output short circuit, over-voltage, over-voltage limitation, undervoltage, ground fault detection, input phase failure, output phase failure, overload protection by electronic thermal function, armature over-current at start-up, load side over-current at start-up, over-torque, undercurrent, overheating, cumulative operation time, life alarm, emergency stop, braking resistor overcurrent / overload, various pre-alarms
Electronic thermal characteristic	Switching between standard motor and constant-torque VF motor, switching between motors 1 & 2, setting of overload trip time, adjustment of stall prevention levels 1 & 2, selection of overload stall
Reset function	Panel reset / External signal reset / Power supply reset. This function is also used to save and clear trip records.
Alarms	Overcurrent, overvoltage, overload, overheat, communication error, under-voltage, setting error, retry in process, upper/lower limits
Causes of failures	Overcurrent, overvoltage, overheat, output short-circuit, ground fault, overload on inverter, arm overcurrent at start-up, overcurrent on the load side at start-up, CPU fault, EEPROM fault, RAM fault, ROM fault, communication error. (Selectable: dynamic braking resistor overload, emergency stop, under-voltage, small current, over-torque, low-torque, motor overload, input phase failure, output phase failure)
Monitoring function	Output frequency, frequency command value, operation frequency command, forward/reverse run, output current, input voltage (DC detection), output voltage, torque, inverter load factor, motor load factor, braking resistor load factor, input power, output power, information on input terminals, information on output terminals, overload and region setting, version of CPU1, version of CPU2, PID feedback value, stator frequency, causes of past trips 1 to 8, parts replacement alarm, cumulative operation time, number of starting
Past trip monitoring function	Stores data on the past eight trips: number of trips that occurred in succession, output frequency, frequency command value, forward/reverse run, output current, input voltage (DC detection), output voltage, information on input terminals, information on output terminals, and cumulative operation time when each trip occurred.
Output for frequency meter	Analog output for meter: 1mA dc full-scale dc ammeter 0 - 20mA (4 to 20mA) output: DC ammeter (allowable load resistance: 600Ω or less) 0 - 10V output: DC voltmeter (allowable load resistance: 1kΩ or more) Maximum resolution: 1/1000
4-digit 7-segments LED	Frequency: inverter output frequency, Alarm: overcurrent pre-alarm "L", overvoltage pre-alarm "P", overload pre-alarm "L", overheat pre-alarm "H", communication pre-alarm "L", Status: inverter status (frequency, cause of activation of protective function, input/output voltage, output current, etc.) and parameter settings. Free-unit display: arbitrary unit (e.g. rotating speed) corresponding to output frequency.
Indicator	Lamps indicating the inverter status by lighting, such as RUN lamp, MON lamp, PRG lamp, % lamp, Hz lamp. The charge lamp indicates that the main circuit capacitors are electrically charged.
Safety function	Safe Torque Off (STO) function according to EN/IEC 61508 SIL2 and ISO 13849-1 category 3 PL"d".
Location of use	Indoors; not exposed to direct sunlight, corrosive gas, explosive gas, flammable gas, oil mist, or dust; and vibration of less than 5.9m/s <sup>2</sup> (10 to 55Hz).
Elevation	3000 m or less (current reduction required over 1000 m) Note 2)
Ambient temperature	-10 to +60°C Note 3)
Storage temperature	-25 to +70°C (Temperature applicable for a short term.)
Relative humidity	5 to 95% (free from condensation and vapor).

Note 1. A chattering (momentary ON/OFF of contact) is generated by external factors of the vibration and the impact, etc. In particular, please set the filter of 10ms or more, or timer for measures when connecting it directly with input unit terminal of programmable controller. Please use the OUT terminal as much as possible when the programmable controller is connected.  
 Note 2. Current must be reduced by 1% for each 100 m over 1000 m. For example, 90% at 2000m and 80% at 3000m.  
 Note 3. When using the inverter in locations with temperatures above 40°C, remove the protective label on the top of the inverter and use the inverter with the output current reduced according to the instruction manual.  
 To align the inverters side-by-side horizontally, remove the protective label on the top of the inverter before use. When using the inverter in locations with temperatures above 40°C, use the inverter with the output current reduced.

# Connection diagram

Standard connection diagram - SINK (Negative) (common:CC)

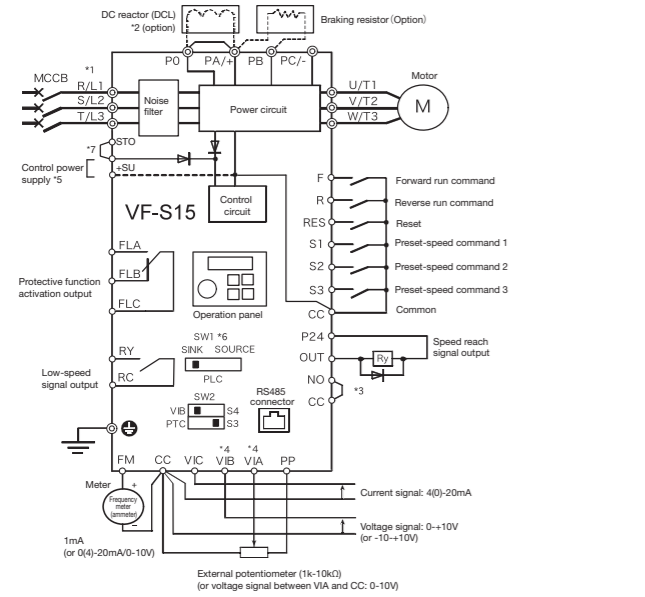

Main circuit power supply  
 3ph-240V class: three-phase 200-240V-50/60Hz  
 1ph-240V class: single-phase 200-240V-50/60Hz  
 3ph-500V class: three-phase 380-500V-50/60Hz  
 \*1: The T/L3 terminal is not provided for single-phase models.  
 Use the R/L1 and S/L2/N terminals as input terminals.  
 \*2: The inverter is supplied with the PO and the PA/+ terminals shorted by means of a shorting bar.  
 Before installing the DC reactor (DCL), remove the bar.

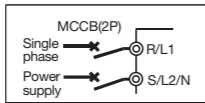

Standard connection diagram - SOURCE (Positive) (common:P24)

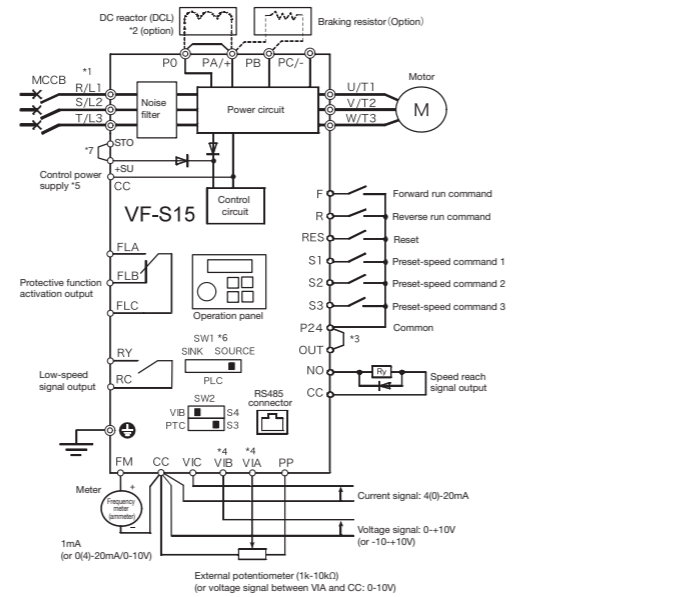

\*3: When using the OUT output terminal in sink logic mode, short the NO and CC terminals. When using the NO output terminal in source logic mode, short the P24 and OUT terminals.  
 \*4: When VIA or VIB terminal is used as logic input terminal, refer to the instruction manual.  
 \*5: To supply control power from an external power supply for backing up the control power supplied from the inverter, an optional control power backup device (CPS002Z) is required. In such a case, the backup device is used at the same time with the internal power supply of the inverter.  
 The optional control power backup unit can be used with both 240V and 500V models.  
 \*6: Set the slide switch SW1 to sink side or source side. Refer to the instruction manual for details. Default setting is PLC side.  
 \*7: When STO terminal is used as compliance with safety standards. Refer to Safety function manual.

## Wiring devices

Voltage class	Applicable motor (kW)	Inverter type	Input current (A)		Molded -case circuit breaker (MCCB) Earth leakage circuit breaker (ELCB) Note3)		Magnetic contactor (MC) Note1)2)		Wire size (mm <sup>2</sup> ) Note5)7)				
			Without DCL	With DCL	Without DCL	With DCL	Without DCL	With DCL	Power circuit Note4)			DC reactor (optional)	Grounding cable Note6)
									Rated current (A)	Rated current (A)	Input		
3-phase 240V	0.4	VFS15-2004PM-W1	3.6	1.8	5	5	20	20	1.5	1.5	1.5	1.5	2.5
	0.75	VFS15-2007PM-W1	6.3	3.4	10	5	20	20	1.5	1.5	1.5	1.5	2.5
	1.5	VFS15-2015PM-W1	11.1	6.5	15	10	20	20	1.5	1.5	1.5	1.5	2.5
	2.2	VFS15-2022PM-W1	14.9	9.2	20	15	20	20	2.5	1.5	1.5	1.5	2.5
	4.0	VFS15-2037PM-W1	23.8	15.9	30	20	32	20	4.0	2.5	2.5	4.0	4.0
	5.5	VFS15-2055PM-W1	35.6	21.5	50	30	50	32	10	4.0	6.0	6.0	10
	7.5	VFS15-2075PM-W1	46.1	28.9	60	40	60	32	16	6.0	10	10	16
	11	VFS15-2110PM-W1	63.1	41.5	100	60	80	50	25	10	16	16	16
1-phase 240V	0.2	VFS15S-2002PL-W1	3.4	2	5	5	20	20	1.5	1.5	1.5	1.5	2.5
	0.4	VFS15S-2004PL-W1	5.9	4	10	5	20	20	1.5	1.5	1.5	1.5	2.5
	0.75	VFS15S-2007PL-W1	10.0	7.6	15	10	20	20	1.5	1.5	1.5	1.5	2.5
	1.5	VFS15S-2015PL-W1	17.8	14.6	30	20	32	20	2.5	2.5	1.5	2.5	2.5
	2.2	VFS15S-2022PL-W1	24	20.1	30	30	32	32	4.0	4.0	1.5	4.0	4.0
3-phase 500V	0.4	VFS15-4004PL1-W1	2.1	0.9	5	5	20	20	1.5	1.5	1.5	1.5	2.5
	0.75	VFS15-4007PL1-W1	3.6	1.8	5	5	20	20	1.5	1.5	1.5	1.5	2.5
	1.5	VFS15-4015PL1-W1	6.4	3.4	10	5	20	20	1.5	1.5	1.5	1.5	2.5
	2.2	VFS15-4022PL1-W1	8.8	4.8	15	10	20	20	1.5	1.5	1.5	1.5	2.5
	4.0	VFS15-4037PL1-W1	13.7	8.3	20	15	20	20	2.5	1.5	1.5	1.5	2.5
	5.5	VFS15-4055PL-W1	20.7	11.2	30	15	32	20	4.0	1.5	2.5	2.5	4.0
	7.5	VFS15-4075PL-W1	26.6	15.1	40	20	32	20	6.0	2.5	2.5	4.0	6.0
11	VFS15-4110PL-W1	36.6	21.7	50	30	50	32	10	4.0	6.0	6.0	10	
15	VFS15-4150PL-W1	47.7	29	60	40	60	32	16	6.0	10	10	16	

Note 1: Be sure to attach a surge absorber to the exciting coil of the relay and the magnetic contactor.  
 Note 2: When using the auxiliary contacts 2a of the magnetic contactor MC for the control circuit, connect the contacts 2a in parallel to increase reliability.  
 Note 3: Select an MCCB with a rated interrupting current appropriate to the capacity of the power supply, because short-circuit currents vary greatly depending on the capacity of the power supply and the condition of the wiring system.  
 The MCCB, MC and ELCB in this table were selected, on the assumption that a power supply with a normal capacity would be used.  
 Note 4: Sizes of the wires connected to the input terminals R/L1, S/L2 and T/L3 and the output terminals U/T1, V/T2 and W/T3 when the length of each wire does not exceed 30m.  
 Note 5: For the control circuit, use shielded wires 0.75 mm<sup>2</sup> or more in diameter.  
 Note 6: For grounding, use a cable with a size equal to or larger than the above.  
 Note 7: The wire sizes specified in the above table apply to HV wires (copper wires shielded with an insulator with a maximum allowable temperature of 75°C) used at an ambient temperature of 50°C or less.

## Power circuit

Terminal symbol	Terminal function
⏏	Grounding terminal for connecting inverter. There are 3 terminals in cooling fin or mounting part of EMC plate.
R/L1, S/L2, T/L3	240V class : Three-phase 200 to 240V-50/60Hz : Single-phase 200 to 240V-50/60Hz 500V class : Three-phase 380 to 500V-50/60Hz * Single-phase inputs are R/L1 and S/L2/N terminals.
U/T1, V/T2, W/T3	Connect to three-phase motor.
PA/+, PB	Connect to braking resistors. Change parameters <i>F 304</i> , <i>F 305</i> , <i>F 308</i> , <i>F 309</i> if necessary.
PA/+	This is a positive potential terminal in the internal DC main circuit. DC common power can be input with PC/- terminal.
PC/-	This is a negative potential terminal in the internal DC main circuit. DC common power can be input with PA/+ terminal.
PO, PA/+	Terminals for connecting a DC reactor (DCL: optional external device). Shorted by a short bar when shipped from the factory. Before installing DCL, remove the short bar.

The arrangements of power circuit terminals are different from each range. Refer to the instruction manual for details.

## Control circuit terminals

Terminal symbol	Input / output	Function	Electrical specifications
F	Input	Shorting across F-CC or P24-F causes forward rotation; open causes deceleration stop. (When Standby ST is always ON) 3 different functions can be assigned.	No voltage logic input 24Vdc-5mA or less
R	Input	Shorting across R-CC or P24-R causes reverse rotation; open causes deceleration stop. (When Standby ST is always ON) 3 different functions can be assigned.	
RES	Input	This inverter protective function is reset if RES-CC or P24-RES is connected. Shorting RES-CC or P24-RES has no effect when the inverter is in a normal condition. 2 different functions can be assigned.	Sink/Source and PLC selectable using slide switch SW1 (Default setting is PLC side)
S1	Input	Shorting across S1-CC or P24-S1 causes preset speed operation. 2 different functions can be assigned.	Pulse train input (S2 terminal) Pulse frequency range: 10pps~2kpps Duty: 50±10%
S2	Input	Shorting across S2-CC or P24-S2 causes preset speed operation. By changing parameter <i>F 145</i> setting, this terminal can also be used as a pulse train input terminal.	PTC input (S3 terminal)
S3	Input	Shorting across S3-CC or P24-S3 causes preset speed operation. By changing slide switch SW2 and parameter <i>F 147</i> setting, this terminal can also be used as a PTC input terminal.	
CC	Common to Input / output	Control circuit's equipotential terminal (3 terminals)	
PP	Output	Analog power supply output	10Vdc (permissible load current: 10mAdc)
VIA Note 1)	Input	Multifunction programmable analog input. Default setting: 0-10Vdc (1/1000 resolution) and 0-60Hz (0-50Hz) frequency input (1/2000 resolution). By changing parameter <i>F 109</i> , this terminal can also be used as a multifunction programmable logic input terminal.	10Vdc (internal impedance: 30kΩ)
VIB Note 1)	Input	Multifunction programmable analog input. Default setting: 0-10Vdc (1/1000 resolution) and 0-60Hz (0-50Hz) frequency input. The function can be changed to -10~+10V input by parameter <i>F 107</i> = 1 setting. By switching slide switch SW2 and changing parameter <i>F 109</i> setting, this terminal can also be used as a multifunction programmable logic input terminal.	10Vdc (internal impedance: 30kΩ)
VIC	Input	Multifunction programmable analog input. 4-20mA (0-20mA) input.	4-20mA (internal impedance: 250Ω)
FM	Output	Multifunction programmable analog output. Default setting: output frequency. The function can be changed to meter option (0-1mA), 0-10Vdc voltage, or 0-20mAdc (4-20mA) current output by parameter <i>F 58</i> setting. Resolution Max. 1/1000.	1mAdc full-scale ammeter or QS60T (option) 0-20mA (4-20mA) DC ammeter Permissible load resistance: 600Ω or less 0-10V DC volt meter Permissible load resistance: 1kΩ or more
P24	Output	24Vdc power output, by changing SW1 to SINK or SOURCE side.	24Vdc-100mA
	Input	This terminal can be used as a common terminal when an external power supply is used by changing SW1 to PLC side.	-
+SU Note 2)	Input	DC power input terminal for operating the control circuit. Connect a control power backup device (option or 24Vdc power supply) between +SU and CC.	Voltage: 24Vdc±10% Current: 1A or more
	Output	It is used with STO for safety function. +SU and STO terminals are short-circuited by metal bar and the inverter is put into a standby state at default setting. When the circuit between them is opened, the motor is coasting stop.	-
STO Note 3)	Input	When +SU and STO are short-circuited, the inverter is put into a standby state. (Default setting) And when the circuit between them is opened, the motor is coasting stop. These terminals can be used for inter lock. This terminal is not a multifunction programmable input terminal. It is a terminal with the safety function that complies with SIL II of the safety standard IEC61508.	Independently of SW1 ON: DC17V or more OFF: DC12V or less (OFF: Coast stop)
OUT NO	Output	Multifunction programmable open collector output. Default setting detect and output speed reach signal. Multifunction output terminals to which two different functions can be assigned. The NO terminal is an equipotential terminal. It is isolated from the CC terminal. By changing parameter <i>F 58</i> settings, these terminals can also be used as multifunction programmable pulse train output terminals.	Open collector output 24Vdc-100mA To output pulse trains, a current of 10mA or more needs to be passed. Pulse frequency range: 10~2kpps
FLA FLB FLC Note 4)	Output	Multifunction programmable relay contact output. Detects the operation of the inverter's protection function. (Default setting) Contact across FLA-FLC is closed and FLB-FLC is opened during protection function operation.	Max. switching capacity 250Vac-2A 30Vdc-2A (cosφ=1) : at resistive load 250Vac-1A (cosφ=0.4) 30Vdc-1A (L/R=7ms) Min. permissible load 5Vdc-100mA 24Vdc-5mA
RY RC Note 4)	Output	Multifunction programmable relay contact output. Default settings detect and output low-speed signal output frequencies. Multifunction output terminals to which two different functions can be assigned.	

Note 1) When VIA terminal is used as logic input terminal, be sure to connect a resistor between P24 and VIA in case of sink logic, between VIA and CC in case of source logic. (Recommended resistance: 4.7kΩ-1/2W) It is not needed for VIB terminal.  
 Note 2) When using a communication option, a diode is required between +SU terminal and Control power supply backup unit or external 24Vdc power supply. (Diode rating: voltage 400V or more, current 1.5A or more)  
 Note 3) When STO terminal is used as the safety function, refer to Safety function manual.  
 Note 4) A chattering (momentary ON/OFF of contact) is generated by external factors of the vibration and the impact, etc. In particular, please set the filter of 10ms or more, or timer for measures when connecting it directly with input unit terminal of programmable controller. Please use the OUT terminal as much as possible when the programmable controller is connected.



# Peripheral devices

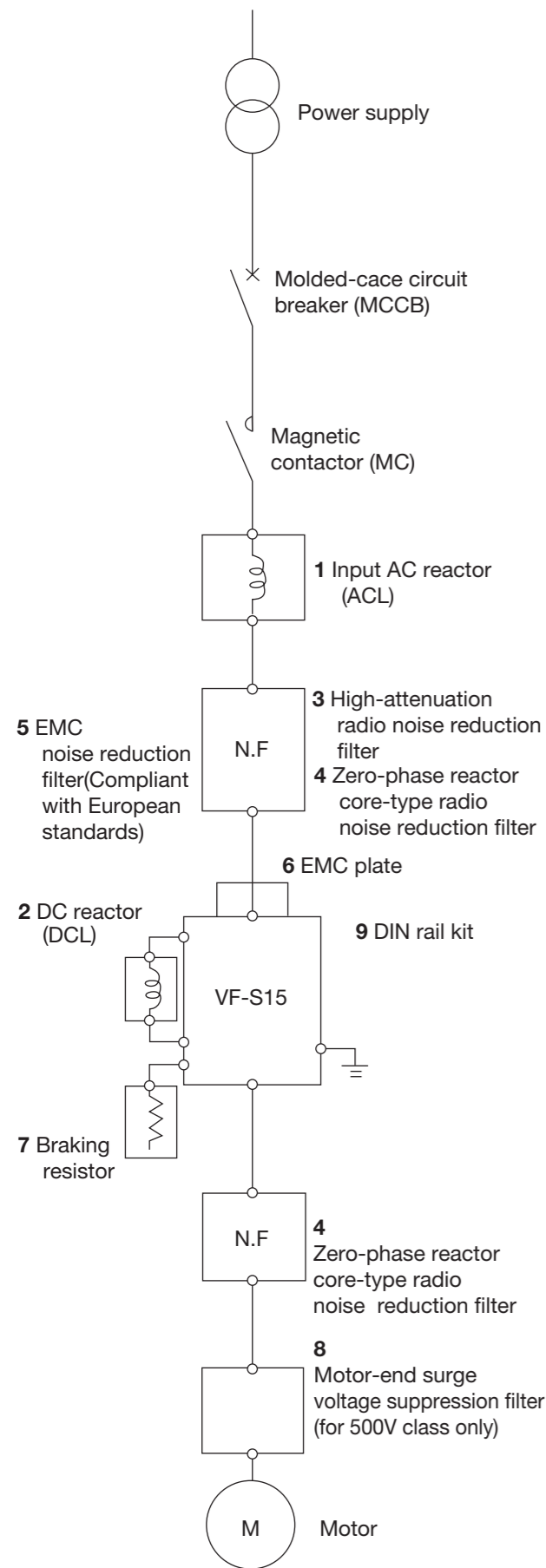

No.	Device	Function and purpose	Refer to															
1	Input AC reactor (ACL)	Used to improve the input power factor, reduce the harmonics, and suppress external surge on the inverter power source side. Install when the power capacity is 500 kVA or more and 10 times or more than the inverter capacity or when a distorted wave generation source such as a thyristor unit or a large-capacity inverter is connected in the same distribution system. <table border="1"> <thead> <tr> <th rowspan="2">Reactor type</th> <th colspan="3">Effect</th> </tr> <tr> <th>Improvement of power factor</th> <th>Suppression of harmonic</th> <th>Suppression of external surge</th> </tr> </thead> <tbody> <tr> <td>Input AC reactor</td> <td>Enabled</td> <td>Enabled</td> <td>Enabled</td> </tr> <tr> <td>DC reactor</td> <td>Enabled (large)</td> <td>Enabled (large)</td> <td>Disabled</td> </tr> </tbody> </table>	Reactor type	Effect			Improvement of power factor	Suppression of harmonic	Suppression of external surge	Input AC reactor	Enabled	Enabled	Enabled	DC reactor	Enabled (large)	Enabled (large)	Disabled	P.17
Reactor type	Effect																	
	Improvement of power factor	Suppression of harmonic	Suppression of external surge															
Input AC reactor	Enabled	Enabled	Enabled															
DC reactor	Enabled (large)	Enabled (large)	Disabled															
2	DC reactor (DCL)	Generally, a DC reactor improves the power factor more than an input AC reactor. When the inverter is used along with equipment for which a high degree of reliability is required, an input AC reactor capable of suppressing external surges should be used along with a DC reactor.	P.17															
3	High-attenuation radio noise filter (NF type)	These types of filters are not necessary because all single-phase 240V or 3-phase 500V models have a built-in EMC noise filter. The built-in filter meets IEC61800-3. But install these filters if necessarily of noise reduction move and more. <ul style="list-style-type: none"> <li>Effective to prevent interference in audio equipment used near the inverter.</li> <li>Install on the input side of the inverter.</li> <li>Provided with wide-range attenuation characteristics from AM radio bands to near 10MHz.</li> <li>Use when equipment readily affected by noise is installed in the peripheral area.</li> </ul>	P.18															
4	Zero-phase reactor core-type	<ul style="list-style-type: none"> <li>Effective to prevent interference in audio equipment used near the inverter.</li> <li>Effective in noise reduction on both input and output sides of the inverter.</li> <li>Provided with attenuation characteristics of several dB in frequencies from AM radio bands to 10MHz.</li> <li>For noise countermeasures, insert on the secondary side of the inverter.</li> </ul>	P.18															
5	EMC noise filter (Compliant with European standards)	A high-attenuation compact EMC noise filter that can be Foot-mounted and Side-mounted. With this filter on, the inverter complies with the following standards.	-															
6	EMC plate	A steel plate used to connect shielded earth wires from inverter's power cables or to connect earth wires from external devices.	P.10															
7	Braking resistor	Use when rapid deceleration or stop is frequently required or when it is desired to reduce the deceleration time with large load. This resistor consumes regenerative energy during power generation braking.	P.18															
8	Motor-end surge voltage suppression filter (for 500V class only)	Use an insulation-reinforced motor or install the surge voltage restraint filter to prevent degrading motor insulation caused by surge voltage generation depending on cable length and wiring method, or use of a 500V class motor driven with an inverter.	P.19															
9	DIN rail kit	Available for the 2.2kW (or 1.5kW) or less.	-															
10	Parameter writer	Use this unit for batch read, batch copy, and batch writing of setting parameters.	P.16															
11	Extension panel	Extended operation panel kit provided with LED indication section, RUN/STOP key, UP/DOWN key, Monitor key, and Enter key.	P.19															
12	USB communication conversion unit	This unit is connected to a PLC or a computer to enable data communications. By connecting the connector cable, parameters can be easily adjusted, and data easily saved and written.	P.16															
13	communication option	These options allow you to connect a upper controller to multiple inverters for data transfer.	P.16															
14	Remote panel	This panel includes a frequency meter, a frequency regulator and RUN/STOP (forward/reverse run) switches.	P.19															

# External options

Voltage class	Inverter model	Applicable motor (kW)	Input AC reactor	DC reactor	Radio noise reduction filter		Braking resistor	Motor-end surge voltage suppression filter	DIN rail
					High-attenuation	Core-type			
3-phase 240V	VFS15-2004PM-W1	0.4	PFL-2005S	DCL3-4015	NF3005A-MJ	RC5078ZZ	PBR-2007	-	DIN003Z
	VFS15-2007PM-W1	0.75	PFL-2005S	DCL3-2007	NF3005A-MJ	RC5078ZZ	PBR-2007	-	DIN003Z
	VFS15-2015PM-W1	1.5	PFL-2011S	DCL3-2015	NF3015A-MJ	RC5078ZZ	PBR-2022	-	DIN005Z
	VFS15-2022PM-W1	2.2	PFL-2011S	DCL3-2022	NF3015A-MJ	RC5078ZZ	PBR-2022	-	DIN005Z
	VFS15-2037PM-W1	4.0	PFL-2018S	DCL3-2037	NF3020A-MJ	RC5078ZZ	PBR-2037	-	-
	VFS15-2055PM-W1	5.5	PFL-2025S	DCL3-2055	NF3030A-MJ	RC9129ZZT	PBR7-004W015	-	-
	VFS15-2075PM-W1	7.5	PFL-2050S	DCL3-2075	NF3040A-MJ	RC9129ZZT	PBR7-004W015	-	-
	VFS15-2110PM-W1	11	PFL-2050S	DCL3-2110	NF3050A-MJ	RC9129ZZT	PBR7-008W7R5	-	-
1-phase 240V	VFS15-2150PM-W1	15	PFL-2100S	DCL3-2150	NF3080A-MJ	RC9129ZZT	PBR7-008W7R5	-	-
	VFS15S-2002PL-W1	0.2	PFL-2005S	DCL3-4015		RC5078ZZ	PBR-2007	-	DIN003Z
	VFS15S-2004PL-W1	0.4	PFL-2005S	DCL3-2007		RC5078ZZ	PBR-2007	-	DIN003Z
	VFS15S-2007PL-W1	0.75	PFL-2011S	DCL3-2015		RC5078ZZ	PBR-2007	-	DIN003Z
	VFS15S-2015PL-W1	1.5	PFL-2018S	DCL3-2037		RC5078ZZ	PBR-2022	-	DIN005Z
	VFS15S-2022PL-W1	2.2	PFL-2018S	DCL3-2037		RC5078ZZ	PBR-2022	-	DIN005Z
	VFS15S-4004PL1-W1	0.4	PFL-4012S	DCL3-4004		RC5078ZZ	PBR-2007	MSF-4015Z	DIN005Z
	VFS15S-4007PL1-W1	0.75	PFL-4012S	DCL3-4007		RC5078ZZ	PBR-2007	MSF-4015Z	DIN005Z
3-phase 500V	VFS15-4015PL1-W1	1.5	PFL-4012S	DCL3-4015		RC5078ZZ	PBR-2007	MSF-4015Z	DIN005Z
	VFS15-4022PL1-W1	2.2	PFL-4012S	DCL3-4022		RC5078ZZ	PBR-2007	MSF-4037Z	-
	VFS15-4037PL1-W1	4.0	PFL-4012S	DCL3-4037		RC5078ZZ	PBR-4037	MSF-4037Z	-
	VFS15-4055PL-W1	5.5	PFL-4025S	DCL3-4055		RC9129ZZT	PBR7-004W060	MSF-4075Z	-
	VFS15-4075PL-W1	7.5	PFL-4025S	DCL3-4075		RC9129ZZT	PBR7-004W060	MSF-4075Z	-
	VFS15-4110PL-W1	11	PFL-4025S	DCL3-4110		RC9129ZZT	PBR7-008W030	MSF-4150Z	-
	VFS15-4150PL-W1	15	PFL-4050S	DCL3-4150		RC9129ZZT	PBR7-008W030	MSF-4150Z	-

The EMC noise filter is built into the 1ph-240V and 3ph-500V models by the standard.

# Communication

Name	Type-form
CC-Link communication option	CCL003Z
PROFIBUS-DP communication option	PDP003Z
PROFINET communication option	PNE001Z
Device Net communication option	DEV003Z
EtherNet/IP - Modbus TCP communication option	IPE002Z
EtherCAT communication option	IPE003Z
CAN open	CAN001Z
Communication D-sub connector (9pins) type	CAN002Z
option	CAN003Z
Open connector (5pins) type	CAN003Z
Communication option adapter	SBP009Z

Mount the option

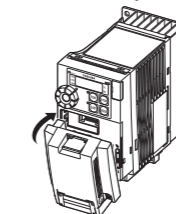

Mount it to the front of inverter. The depth is increase 25mm.

# Operation option

## USB communication conversion unit

Type-form: USB001Z  
Inverter can be management and setting on a PC

### Connection

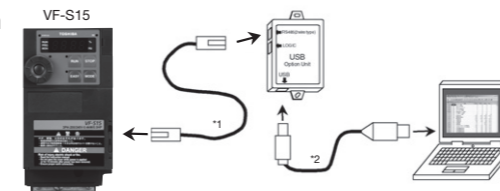

\*1: USB communication conversion unit cable. Type-form (inverter side): CAB0011(1m), CAB0013(3m), CAB0015(m)  
\*2: Cable is USB cable (USB1.1/2.0 A-B connect type) for PC side.

### Dimension

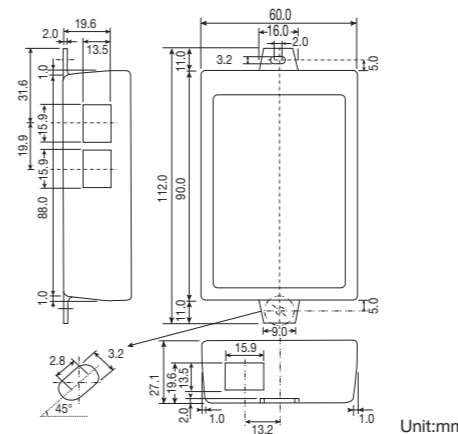

## Parameter writer

Type-form: PWU003Z

Parameter can be read/write without power supply to the inverter. And inverter can be management and setting on a PC.

### Connect to inverter



### Outline drawing

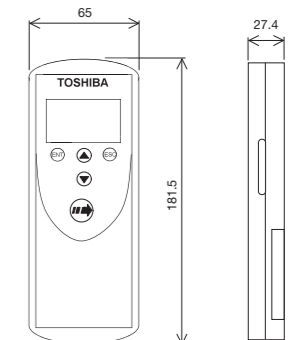

## Read/write/restore of parameters

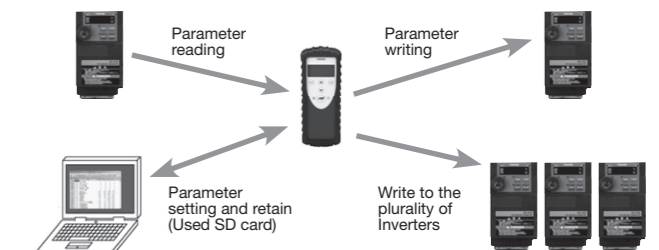

## Specification

Items	Specification
Battery	AA size battery or Nickel metal hydride: Used 4 batteries Note) Batteries are not attached
languages	Japanese, English, Spanish, German, Italian, French
Data storage	SD card, SDHC card (Format is FAT32)
Attachment	USB cable, RJ45 cable(1m), SD card, Carry case, Shock-absorb cover, Wrist strap, Manual(Japanese/English)

## Dimension and Connection

### Input AC reactor

#### Dimension

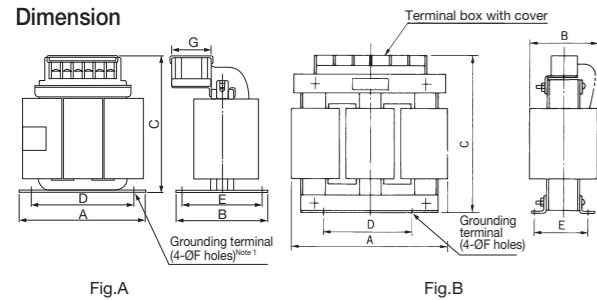
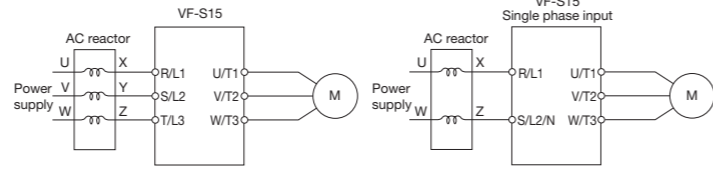

Fig.A

Fig.B

#### Connection



Note 1: Use the portion where the varnish around the installation hole is removed for wiring grounding wire.

Reactor model	Rating	Inverter model	Dimensions (mm)							Diagram	Terminals	Approx. mass (kg)
			A	B	C	D	E	F	G			
PFL-2005S	3-phase 240V class -5.5A-50/60Hz	VFS15-2004PM-W1, 2007PM-W1, VFS15S-2002PL-W1, 2004PL-W1	105	65	115	90	55	5	40	A	M3.5	1.2
PFL-2011S	3-phase 240V class -11A-50/60Hz	VFS15-2015PM-W1, 2022PM-W1, VFS15S-2007PL-W1	130	70	140	115	60	5	50		M4	2.3
PFL-2018S	3-phase 240V class -18A-50/60Hz	VFS15-2037PM-W1, VFS15S-2015PL-W1, 2022PL-W1	130	70	140	115	60	5	50		M4	2.5
PFL-2025S	3-phase 240V class -25A-50/60Hz	VFS15-2055PM-W1	125	100	130	50	83	7	-	B	M4	2.6
PFL-2050S	3-phase 240V class -50A-50/60Hz	VFS15-2075PM-W1, 2110PM-W1	155	115	140	50	95	7	-		M6	3.4
PFL-2100S	3-phase 240V class -100A-50/60Hz	VFS15-2150PM-W1	230	150	210	60	90	8	-		M8	8.2
PFL-4012S	3-phase 500V class -12.5A-50/60Hz	VFS15-4004PL1-W1~4037PL1-W1	125	95	130	50	79	7	-	B	M4	2.3
PFL-4025S	3-phase 500V class -25A-50/60Hz	VFS15-4055PL-W1~4110PL-W1	155	110	155	50	94	7	-		M4	4.9
PFL-4050S	3-phase 500V class -50A-50/60Hz	VFS15-4150PL-W1	155	140	165	50	112	7	-		M6	6.6

### DC reactor

#### Dimension

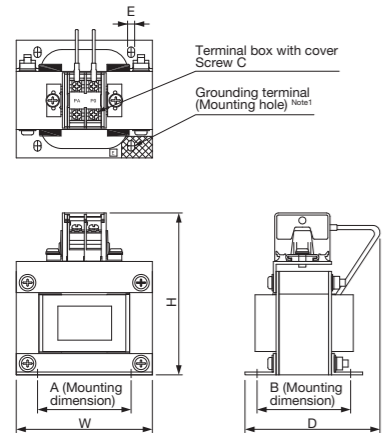

#### Connection

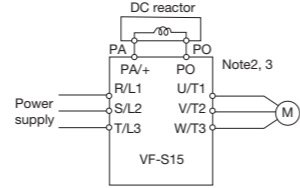

Note 1: Use the portion where the varnish around the installation hole is removed for wiring grounding wire.  
 Note 2: Remove the jumper across terminals PO-PA+.  
 Note 3: Maximum wire length is 5m.

Reactor model	Inverter model	Dimensions(mm)							Approx. mass (kg)
		W	H	D	A	B	C	E	
DCL3-2007	VFS15-2007PM-W1, VFS15S-2004PL-W1	75	116	78	54	51	M4	5	1.0
DCL3-2015	VFS15-2015PM-W1, VFS15S-2007PL-W1								1.0
DCL3-2022	VFS15-2022PM-W1								1.1
DCL3-2037	VFS15-2037PM-W1, VFS15S-2015PL-W1, 2022PL-W1	96	118	100	66	66	M4	5	2.2
DCL3-2055	VFS15-2055PM-W1								2.2
DCL3-2075	VFS15-2075PM-W1	120	134	116	86	76	M5	5	3.6
DCL3-2110	VFS15-2110PM-W1	144	180	128	104	83	M6	7	5.7
DCL3-2150	VFS15-2150PM-W1								6.1
DCL3-4004	VFS15-4004PL1-W1	75	116	78	54	51	M4	5	1.0
DCL3-4007	VFS15-4007PL1-W1								1.0
DCL3-4015	VFS15-2004PM-W1, VFS15S-2002PL-W1, VFS15-4015PL1-W1								1.0
DCL3-4022	VFS15-4022PL1-W1	96	118	97	66	66	M4	5	1.1
DCL3-4037	VFS15-4037PL1-W1								2.2
DCL3-4055	VFS15-4055PL-W1	120	134	116	86	76	M5	5	3.4
DCL3-4075	VFS15-4075PL-W1								3.5
DCL3-4110	VFS15-4110PL-W1	144	180	128	104	83	M6	7	5.8
DCL3-4150	VFS15-4150PL-W1			132					6.5

### High attenuation radio noise reduction filter

#### Dimension

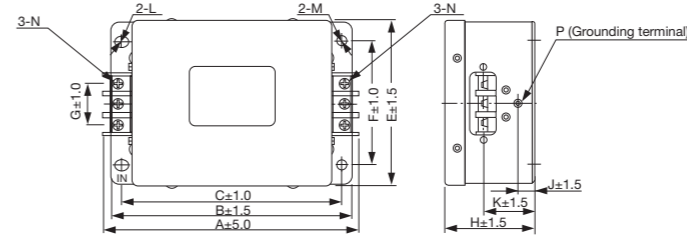

#### Connection

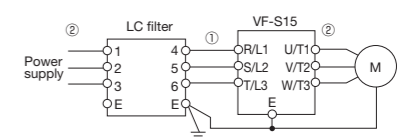

Note: (1) Noise filter should be connected to the inverter main circuit primary side.  
 (2) Output wire should be kept away from the input wire.

Filter model	Rated current (A)	Inverter model	Dimensions (mm)																	Approx. mass (kg)
			A	B	C	E	F	G	H	J	K	L	M	N	P					
NF3005A-MJ	5	VFS15-2004PM-W1~2007PM-W1, VFS15S-2002PL-W1	174.5	160	145	110	80	32	70	20	45	R2.75	Length 7	Ø5.5	M4	M4	1.0			
NF3015A-MJ	15	VFS15-2015PM-W1, 2022PM-W1, VFS15S-2004PL-W1~2015PL-W1															1.6			
NF3020A-MJ	20	VFS15-2037PM-W1															1.6			
NF3030A-MJ	30	VFS15-2055PM-W1, VFS15S-2022PL-W1	217.5	200	185	120	90	44	70	20	43	R3.25	Length 8	Ø6.5	M6	M4	2.7			
NF3040A-MJ	40	VFS15-2075PM-W1															4.6			
NF3050A-MJ	50	VFS15-2110PM-W1	267.5	250	235	170	140	57	100	30	65	R2.75	Length 7	Ø5.5	M4	M4	7.0			
NF3080A-MJ	80	VFS15-2150PM-W1	294.5	280	260	200	150	32	70	20	45						M6	M4	2.7	
NF3010C-MJ	10	VFS15-4004PL1-W1~4037PL1-W1	174.5	160	145	110	80	32	70	20	45	R2.75	Length 7	Ø5.5	M4	M4	1.4			
NF3015C-MJ	15	VFS15-4055PL-W1															1.6			
NF3020C-MJ	20	VFS15-4075PL-W1															1.6			
NF3030C-MJ	30	VFS15-4110PL-W1	214	200	185	120	90	32	70	20	43	M5	M4	M4	M4	1.6				
NF3040C-MJ	40	VFS15-4150PL-W1	217.5													44	1.6			

Note: For the inverter models ending with -PL, same noise filter as the ones described here is built-in standard.

### Zero-phase reactor core-type radio noise filter

#### Type-form: RC5078ZZ

##### Dimension

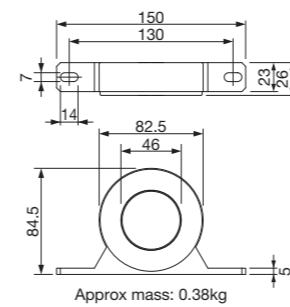

#### Type-form: RC9129ZZT

##### Dimension

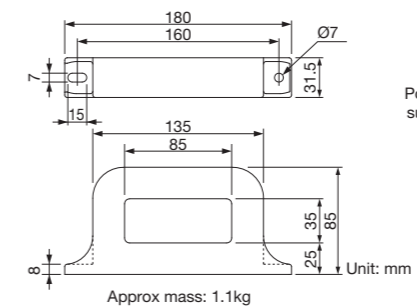

#### Connection

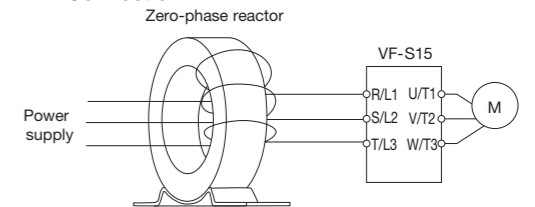

- Go the wires of each phase through the reactor at once and coil it in the same direction.  
 - In case of using for input side, coil wires four times or more, or go wires through four or more reactors.  
 - In case of using for output side, coil wires four times or more. When the wiring between the inverter and the motor is long (50m or more), use wires with high permissible temperature or go wires through four or more reactors.  
 - RC5078ZZ is recommended for the models 4.0kW or less.

### Braking resistor

#### Dimension

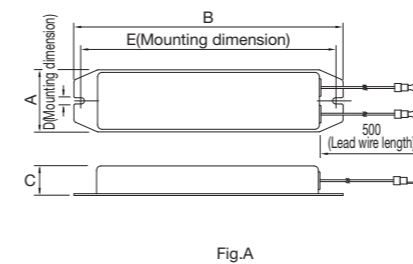

Fig.A

#### Connection

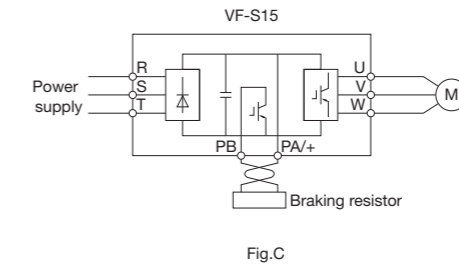

Fig.C

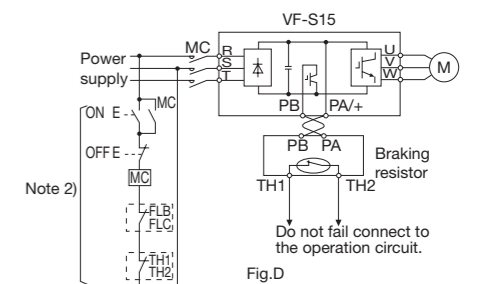

Fig.D

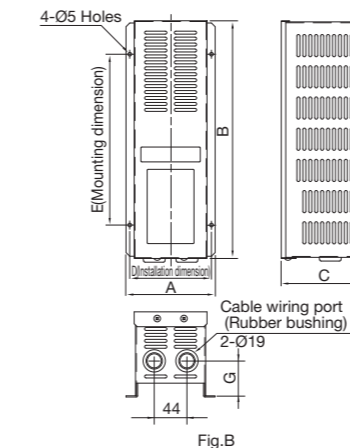

Fig.B

Resistor model	Rating	Inverter model	Dimensions (mm)							External dimension/Con- nection diagram	Approx. mass (kg)
			A	B	C	D	E	G			
PBR-2007	120W-200Ω	VFS15-2004PM-W1~2007PM-W1, VFS15S-2002PL-W1~2007PL-W1, VFS15-4004PL1-W1~4022PL1-W1 (Note1)	42	182	20	4.2	172	-	A & C	0.28	
PBR-2022	120W-75Ω	VFS15-2015PM-W1, 2022PM-W1, VFS15S-2015PL-W1, 2022PL-W1									
PBR-2037	120W-40Ω	VFS15-2037PM-W1									
PBR-4037	120W-160Ω	VFS15-4037PL1-W1	120	320	115	110	230	48	B & D	3.4	
PBR7-004W015	440W-15Ω	VFS15-2055PM-W1, 2075PM-W1									
PBR7-004W060	440W-60Ω	VFS15-4055PL-W1, 4075PL-W1									
PBR7-008W7R5	880W-7.5Ω	VFS15-2110PM-W1, 2150PM-W1									
PBR7-008W030	880W-30Ω	VFS15-4110PL-W1, 4150PL-W1	120	350	190	110	230	150	-	5.4	

Note1: Braking resistors for VFS15-4004PL1-W1~4022PL1-W1 are the same type of those for VFS15-2004PM-W1~2007PM-W1.  
 Note2: In case of 500V class, please apply the 200V to the operation circuit by using control transformer or 200V power supply.

## Motor end surge voltage suppression filter (for 500V class only)

Filter model	Applicable motor (kW)	Dimensions (mm)			Terminal screw	Grounding screw	Approx. mass (kg)
		W	H	D			
MSF-4015Z	0.4,0.75,1.5	310	255	300	M4	M4	12
MSF-4037Z	2.2,4.0	310	255	300	M4	M4	20
MSF-4075Z	5.5,7.5	310	315	350	M5	M4	30
MSF-4150Z	11,15	330	355	400	M6	M5	40

### Connection

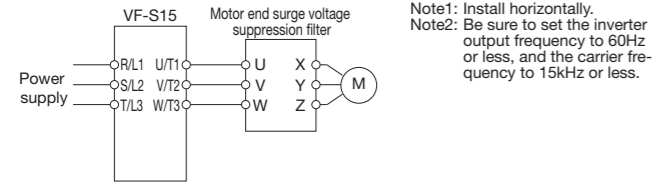

## Extension panel

### Type-form: RKP002Z (It has parameter copy function)

Dimension Panel cutout dimension

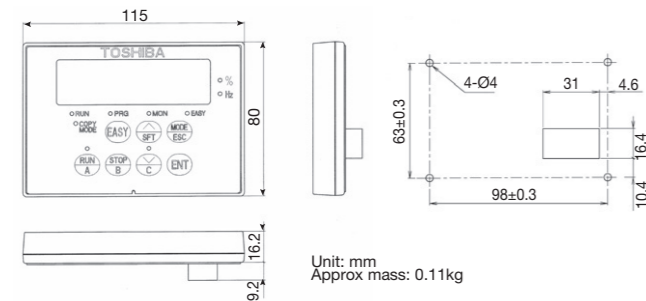

Communication cable model: CAB0011 (1m), CAB0013 (3m), CAB0015 (5m)

## Control power supply backup unit

### Type-form: CPS002Z 240V/500V

Dimension Connection

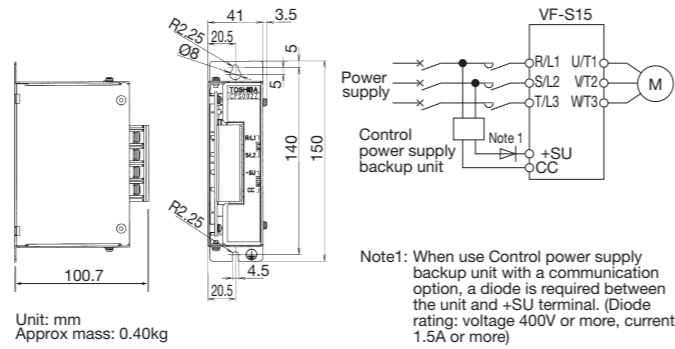

### Type-form: RKP007Z

Dimension Panel cutout dimension

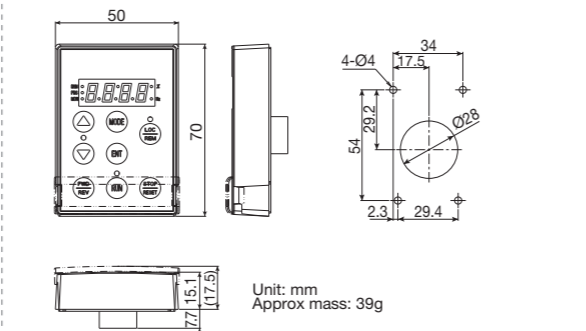

Communication cable model: CAB0071 (1m), CAB0073 (3m), CAB0075 (5m)

## Remote panel

### Type-form: CBVR-7B1

Dimension Panel cutout dimension Connection

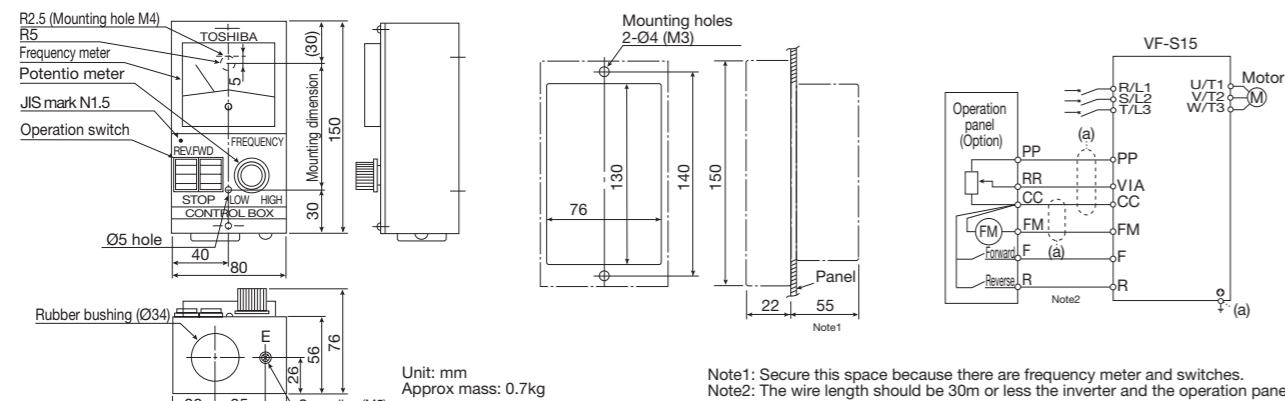

## Frequency meter

### Type-form: QS60T

Dimension Panel cutout dimension

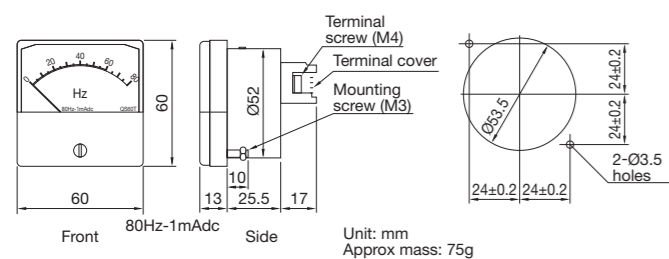

## FRH kit

### Type-form: FRH-KIT\*K

• Frequency setting resistor (RV30YN-20S-B302)

Dimension Panel cutout dimension

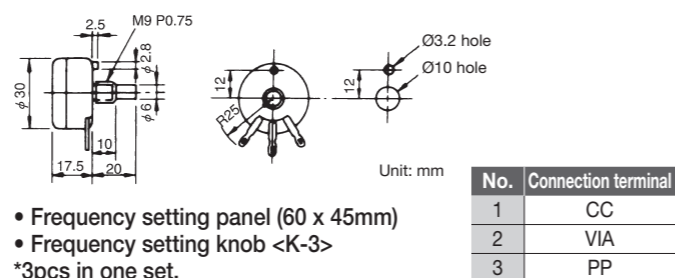

- Frequency setting panel (60 x 45mm)
  - Frequency setting knob <K-3>
- \*3pcs in one set.

No.	Connection terminal
1	CC
2	VIA
3	PP

# To users of our inverters

## 1. For inverter users

### Notes

### Leakage current

This inverter uses high-speed switching semiconductor for PWM control. When a relatively long cable is used for power supply to an inverter, current may leak from the cable or the motor to the ground because of its capacitance, adversely affecting peripheral equipment. Installation of radio noise reduction filter may also increase leakage current. The intensity of such a leakage current depends on the PWM carrier frequency setting, the lengths of the input and output cables, etc., of the inverter. To prevent current leakage, it is recommended to take the following measures.

### [Effects of leakage current]

Leakage current which increases when an inverter is used may pass through the following routes:

- Route (1) ... Leakage due to the capacitance between the ground and the noise reduction filter
- Route (2) ... Leakage due to the capacitance between the ground and the inverter
- Route (3) ... Leakage due to the capacitance between ground and the cable connecting the inverter and the motor
- Route (4) ... Leakage due to the capacitance of the cable connecting the motor and an inverter in another power distribution line
- Route (5) ... Leakage through the grounding line common to motors
- Route (6) ... Leakage to another line because of the capacitance of the ground

Leakage current which passes through the above routes may cause the following troubles.

- Malfunction of a leakage circuit breaker (ELCB) in the same or another power distribution line
- Malfunction of a ground-relay installed in the same or another power distribution line
- Noise produced at the output of an electronic device in another power distribution line
- Activation of an external thermal relay installed between the inverter and the motor, at a current below the rated current.

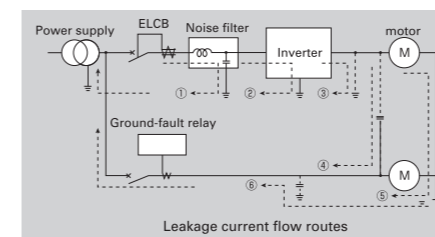

### [Measures against effects of leakage current]

The measures against the effects of leakage current are as follows:

- 1) Measures to prevent the malfunction of leakage circuit breakers (ELCB)
  - (1) Decrease the PWM carrier frequency of the inverter. (Note)
  - (2) Use radio-frequency interference-proof ELCBs as ground-fault interrupters

in not only the system into which the inverter is incorporated but also other systems. When ELCBs are used, the inverter can operate with high PWM carrier frequency.

- (3) When connecting multiple inverters to a single ELCB, use an ELCB with a high current sensitivity or reduce the number of inverters connected to the ELCB.
- 2) Measures against malfunction of ground-fault relay:
  - (1) Decrease the PWM carrier frequency of the inverter. (Note)
  - (2) Install ground-fault relays with a high-frequency protective function in both the same and other lines. When ELCBs are used, the inverter can operate with high PWM carrier frequency.
- 3) Measures against noise produced by other electric and electronic systems:
  - (1) Separate the grounding line of the inverter from that of the affected electric and electronic systems.
  - (2) Decrease the PWM carrier frequency of the inverter. (Note)
- 4) Measures against malfunction of external thermal relays:
  - (1) Remove the external thermal relay and use the electronic thermal function of the inverter instead. (Not apply to cases where a single inverter is used to drive more than one motor. Refer to the instruction manual for measures to be taken when thermal relays cannot be removed.)
  - (2) Decrease the PWM carrier frequency of the inverter. (Note)
- 5) Measures by means of wiring and grounding
  - (1) Separate the inverter's grounding wire from that of other systems or install the grounding wire of each system separately to the grounding point.
  - (2) Use the shortest possible cables (100m or less) to connect the inverter to the motor. If the wire length is long, especially with the models of 4.0kW or less, perhaps over current trip occurs by charging current through the capacitance of cable. Use the separate cable to reduce the capacitance of cable, or install the reactor or the filter between the inverter and the motor as counter-measures against over current trip.
  - (3) If the inverter has a high-attenuation EMC noise reduction filter, change the grounding capacitor switch to reduce the leakage current. Note that doing so leads to a reduction in the noise attenuating effect.

Note) In the case of this inverter, the PWM carrier frequency can be decreased to 2.0kHz. Decrease the carrier frequency results in an increase in electromagnetic noise from the motor.

## Ground fault

Before beginning operation, thoroughly check the wiring between the motor and the inverter for incorrect wiring or short circuits. Do not ground the neutral point of any star-connected motor.

## Radio interference

### [Noise produced by inverters]

Since this inverter performs PWM control, it produces noise and sometimes affects nearby instrumental devices, electrical and

electronic systems, etc. The effects of noise greatly vary with the noise resistance of each individual device, its wiring condition, the distance between it and the inverter, etc.

### [Measures against noises]

According to the route through which noise is transmitted, the noises produced by an inverter are classified into transmission noise, induction noise and radiation noise.

### [Examples of protective measures]

- Separate the power line from other lines, such as weak-current lines and signal lines, and install them apart from each other.
- Install a noise reduction filter in each inverter. It is effective for noise prevention to install noise reduction filters in other devices and systems, as well.
- Shield cables and wires with grounded metallic conduits, and cover electronic systems with grounded metallic cases.
- Separate the power distribution line of the inverter from that of other devices and systems.
- Install the input and output cables of the inverter apart from each other.
- Use shielded twisted pair wires for wiring of the weak-current and signal circuits, and always ground one of each pair of wires.
- Ground the inverter with grounding wires as large and short as possible, separately from other devices and systems.

On 1ph-240V and 3ph-500V models, noise can be greatly reduced as they have a built-in EMC noise reduction filter on their input side.

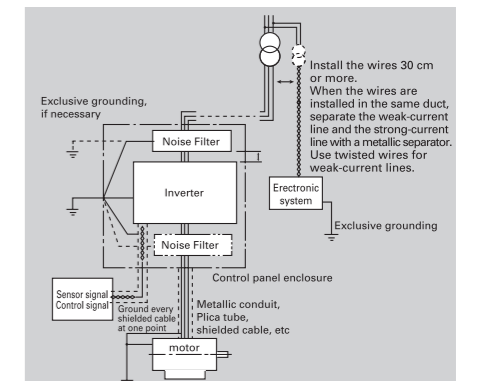

## Power factor improvement capacitors

Do not install power factor improvement capacitors on the output side of the inverter. Installing a power factor improvement capacitor on the output side causes current containing harmonic components to flow into the capacitor, adversely affecting the capacitor itself or causing the inverter to trip. To improve the power factor, install a DC reactor or an input AC reactor on the primary side of the inverter.

## Installation of input AC reactors

These devices are used to improve the input power factor and suppress high harmonic currents and surges. Install an input AC reactor when using this inverter under the following conditions:

- (1) When the power source capacity is 500kVA or more, and when it is 10 times or more greater than the inverter capacity.

- When the inverter is connected the same power distribution system as a thyristor-committed control equipment.
- When the inverter is connected to the same power distribution system as that of distorted wave-producing systems, such as arc furnaces and large-capacity inverters.

## 2. Selecting the Capacity (model) of the Inverter

### Selection

### [Capacity]

Refer to the applicable motor capacities listed in the standard specifications. When driving a high-pole motor, special motor, or multiple motors in parallel, select such an inverter that the sum of the motor rated current multiplied by 1.05 to 1.1 is less than the inverter's rated output current value.

### [Acceleration/deceleration times]

The actual acceleration and deceleration times of a motor driven by an inverter are determined by the torque and moment of inertia of the load, and can be calculated by the following equations.

The acceleration and deceleration times of an inverter can be set individually. In any case, however, they should be set longer than their respective values determined by the following equations.

Acceleration time	$t_a = \frac{(JM+JL) \times \Delta N}{9.56 \times (TM-TL)} \text{ (sec.)}$
Deceleration time	$t_d = \frac{(JM+JL) \times \Delta N}{9.56 \times (TB+TL)} \text{ (sec.)}$
Conditions	<p>JM :Moment of inertia of motor (kg·m<sup>2</sup>)            JL :Moment of inertia of load (kg·m<sup>2</sup>)            (converted into value on motor shaft)            ΔN :Difference in rotating speed between before and after acc. or dec. (min<sup>-1</sup>)            TL :Load torque (N·m)            TM :Motor rated torque x            1.2~1.3 (N·m) ...V/f control            :Motor rated torque x            1.5 (N·m) ...Vector operation control            (In case of variable torque characteristic            TM :Motor rated torque x            1.1 (N·m) ...V/f control            :Motor rated torque x            1.2 (N·m) ...Vector operation control)            TB :Motor rated torque x 0.2 (N·m)            (When a braking resistor or a braking resistor unit is used: Motor rated torque x 0.8-1.0 (N·m))</p>

### [Allowable torque characteristics]

When a standard motor is combined with an inverter to perform variable speed operation, the motor temperature rises slightly higher than it normally does during commercial power supply operation. This is because the inverter output voltage has a sinusoidal (approximate) PWM waveform. In addition, the cooling becomes less effective at low speed, so the torque must be reduced according to the frequency. Regarding the allowable torque characteristic, please confirm with the motor manufacturer.

When constant-torque operation must be performed at low speeds, use a Toshiba constant-torque motor designed specifically for use with inverters.

### [Starting characteristics]

When a motor is driven by an inverter, its operation is restricted by the inverter's overload current rating, so the starting characteristic is different from those obtained from commercial power supply operation.

Although the starting torque is smaller with an inverter than with the commercial power supply, a high starting torque can be produced at low speeds by adjusting the V/f pattern torque boost amount or by employ-

ing vector control. When a larger starting torque is necessary, select an inverter with a larger capacity and examine the possibility of increasing the motor capacity.

## 3. When installing, wiring and operating the inverter

### Installing and wiring

#### [Installing precautions]

- Do not install in any location of high temperature, high humidity, moisture condensation and freezing. Do not install the inverter where there are gases that corrode metal or solvents that adversely affect plastic. Avoid locations where there is exposure to water and/or where there may be large amounts of dust and metallic fragments. In this case, please install inverters in the enclosure type cabinet. The cabinet must be considered its size and the cooling method to allow the specifications of an ambient temperature for inverters.
- Must be installed in non-inflammables such as metals. The rear panel gets very hot. If installation is in an inflammable object, this can result in fire.
- Inverters should be arranged in horizontal rows.

#### [Wiring precautions]

#### Installing a molded-case circuit breaker [MCCB]

- Install a molded-case circuit breaker (MCCB) on the inverter's power supply input to protect the wiring.
- Avoid turning the molded-case circuit breaker on and off frequently to turn on/off the motor. To turn on/off the motor frequently, close/break the control terminals F (or R)-CC.

#### Installing a magnetic contactor [MC] [primary side]

- To prevent an automatic restart after the power interruption or overload relay has tripped, or actuation of the protective circuit, install an electro-magnetic contact in the power supply.
- The inverter is provided with a failure detection relay (FL), so that, if its contacts are connected to the operation circuit of the magnetic contactor on the primary side, the magnetic contactor will be opened when the protective circuit of the inverter is activated.
- The inverter can be used without a magnetic contactor. In this case, use an MCCB (equipped with a voltage tripping device) for opening the primary circuit when the inverter protective circuit is activated.
- Avoid turning the magnetic contactor on and off frequently to turn on/off the motor. To turn on/off the motor frequently, close/break the control terminals F (or R)-CC.
- Install surge suppressor on any magnetic contactor and relay coils used around the inverter.
- If using a braking resistor, install a magnetic contactor (MC) to the power supply of the inverter, so that the power circuit opens when the internal overload relay of the braking resistor is activated.

#### Installing a magnetic contactor [MC] [secondary side]

- As a rule, if a magnetic contactor is installed between the inverter and the motor, do not turn on/off while running. (If the secondary-side contactor is turned on/off while running, a large current may

flow in the inverter, causing inverter damage and failure.)

- A magnetic contactor may be installed to change the motor or change to the commercial power source when the inverter is stopped. Always use an interlock with the magnetic contactor in this situation so that the commercial power supply is not applied to the inverter's output terminals.

#### External signal

- Use a relay rated for low currents. Mount a surge suppressor on the excitation coil of the relay.
- When wiring the control circuit, use shielded wires or twisted pair cables.
- Because all of the control terminals except FLA, FLB, FLC, RY or RC are connected to electronic circuits, insulate these terminals to prevent them from coming into contact with the main circuit.

#### Installing an overload relay

- This inverter has an electronic-thermal overload protective function. However, in the following cases, the thermal relay operation level must be adjusted or an overload relay matching the motor's characteristics must be installed between the inverter and the motor.
  - When using a motor having a rated current value different from that of the equivalent.
  - When driving several motors simultaneously.
- When using the inverter to control the operation of a constant-torque motor, change the protective characteristic of the electronic thermal relay according to the setting of the constant-torque motor.
- In order to adequately protect a motor used for low-speed operation, we recommend the use of a motor equipped with an embedded thermal relay.

#### Wiring

- Do not connect input power to the output (motor side) terminals (U/T1, V/T2, W/T3). That will destroy the inverter and may result in fire. Please pay attentions of wiring before power supply turns-on.
- The DC terminals (PA/+, PO and PB) are for specified options. Do not connect other devices to these terminals.
- Within 15 minutes after turning off input power, do not touch wires of devices (MCCB) connected to the input side of the inverter.

#### Grounding

The inverters and motors must be connected to ground securely. In case of grounding for inverters, please use the grounding terminal of the inverter.

### Operating precautions

- When the inverter operates in abnormal circumstances, the protective function activates to shut off the inverter output. However, the inverters can not stop the motors quickly. Please install the mechanical brake or maintenance function in the mechanical equipment and the device for which the emergency stop is necessary.
- When you drive the machine and the device that hangs the load repeatedly with the inverter, the semiconductor within inverter might cause thermal fatigue and it come to have a short life if a big current flows repeatedly when driving and stopping. In this case, it is possible to extend life span by controlling the start-

ing current and the load current low or setting the PWM career frequency low. If you can not decrease the starting current, please select larger capacity of inverters for current margins.

## 4. When changing the motor speed

### Application to standard motors

#### Vibration

When a motor is operated with an inverter, it experiences more vibrations than when it is operated by the commercial power supply. The vibration can be reduced to a negligible level by securing the motor and machine to the base firmly. If the base is weak, however, the vibration may increase at a light load due to resonance with the mechanical system. In this case, using jump frequency to avoid resonant frequencies or changing PWM carrier frequency is also effective.

#### Acoustic noise

The magnetic noise of motors with inverter drives is changed by PWM carrier frequency. In case of high PWM carrier frequency settings, its acoustic noise is almost same as commercial power supply drives. Moreover, when the motors are operated over rated rotation, the windy noise of the motors is increased.

#### Reduction gear, belt, chain

Note that the lubrication capability of a reducer or a converter used as the interface of the motor and the load machine may affect at low speeds.

When operating at frequencies exceeding 60 Hz or higher, power transmission mechanisms such as reduction gear, belts and chains, may cause problems such as production of noise, a reduction in strength, or shortening of service life.

#### Frequency

Before setting the maximum frequency to over 60 Hz, confirm that this operating range is acceptable for the motor.

#### Starting method

When you drive the motor with changeable connection between star-connection and delta-connection for decreasing starting current, please connect delta-connection only. If you change motor connection while inverter drives, the protective function of inverter activates.

### Application to special motors

#### Geared motor

When using an inverter to drive a geared motor, inquire of the motor manufacturer about its continuous operation range due to the followings:

- The low-speed operation of a geared motor may cause insufficient lubrication
- The loss of a gear may be increased than commercial power supply drives.
- In case of the operation on high frequency exceeding 60Hz, the acoustic noise and motor temperature may be higher.

#### Pole-changing motor

Pole-changing motors can be driven by this inverter. Before changing poles, however, be sure to let the motor come to a complete stop. If you change motor connection while inverter drives, the protective function of inverter may activate.

#### Underwater motors

Note that underwater motors have higher rated current than general motors. The current ratings of underwater motors are relatively high. So, when selecting an inverter, you must pay special attention to its current rating so that the current rating of the motor is below that of the inverter. When the lengths of the motor cable are long, please use thicker cable than a table of "Wiring devices" because the maximum torque is decreased by the voltage dropping. Moreover, please pay attention to select leakage circuit breakers.

#### Single-phase motor

Because single-phase motors are equipped with a centrifugal switch and capacitors for starting, they cannot be driven by an inverter. When single phase motors are driven by inverters, a centrifugal switch and capacitors may be broken. In case of a single-phase, power system, a 3-phase motor can be driven by using a single-phase input inverter to convert it into a 3-phase 200V output. (A special inverter and a 3-phase 200V motor are required.)

#### Brake motor

When using a brake motor, if the braking circuit is directly connected to the inverter's output terminals, the brake cannot be released because of the lowered starting voltage. Therefore, when using a brake motor, connect the braking circuit to the inverter's power supply side, as shown on the below. Usually, brake motors produce larger noise in low speed ranges.

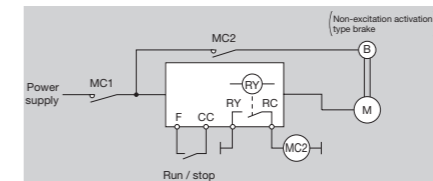

## 5. Disposal of the inverter

For safety's sake, do not dispose of the disused inverter yourself but ask an industrial waste disposal agent. Disposing of the inverter improperly could cause its capacitor to explode and emit toxic gas, causing injury to persons.

**For users of the products :** Our variable speed drives are designed to control the speeds of three-phase motors for general industry.

#### **Precautions**

- \* Please read the instruction manual before installing or operating the drive unit.
- \* This product is intended for general purpose uses in industrial application. It cannot be used applications where may cause big impact on public uses, such as power plant and railway, and equipment which endanger human life or injury, such as nuclear power control, aviation, space flight control, traffic, safety device, amusement, or medical.  
It may be considerable whether to apply, under the special condition or an application where strict quality control may not be required. Please contact our headquarters, branch, or local offices printed on the front and back covers of this catalogue.
- \* When exporting Toshiba variable speed drive separately or combined with your equipment, please be sure to satisfy the objective conditions and inform conditions listed in the export control policies, so called Catch All restrictions, which are set by the Ministry of Economy, Trade and Industry of Japan, and the appropriate export procedures must also be taken.
- \* Please use our product in applications where do not cause serious accidents or damages even if product is failure, or please use in environment where safety equipment is applicable or a backup circuit device is provided outside the system.
- \* Please do not use our product for any load other than three-phase motors.
- \* None of Toshiba, its subsidiaries, affiliates or agents, shall be liable for any physical damages, including, without limitation, malfunction, anomaly, breakdown or any other problem that may occur to any apparatus in which the Toshiba variable speed drive is incorporated or to any equipment that is used in combination with the Toshiba variable speed drive. Nor shall Toshiba, its subsidiaries, affiliates or agents be liable for any compensatory damages resulting from such utilization, including compensation for special, indirect, incidental, consequential, punitive or exemplary damages, or for loss of profit, income or data, even if the user has been advised or apprised of the likelihood of the occurrence of such loss or damages.

For further information, please contact your nearest Toshiba Representative or International Operations-Producer Goods.  
The information in this brochure is subject to change without notice.

## Toshiba Industrial Products and Systems Corporation

Global Sales Department Motor Drive Division

580, Horikawa-cho, Saiwai-ku, Kawasaki, Kanagawa 212-0013, Japan Tel: +81-44-520-0828 Fax: +81-44-520-0508

<http://www.toshiba-tips.co.jp/en/>

CKVJ-1262

2019-08 