



ISOMAG 

The friendly magmeter

DATA SHEET



MS 2500

CE

ISOIL 
INDUSTRIA



INDEX

TECHNICAL DATA	2
97/23/CE PED DIRECTIVE	3
OVERALL DIMENSIONS	4
SEPARATE VERSION	8
INSTALLATION RECOMMENDATIONS	9
RECOMMENDED INSTALLATION PROCEDURE	10
SENSOR GROUNDING	11
PRESSURE LOSS CALCULATION (CONES 8° ANGLES)	12
MI-001 OIML R49 CLASS1: MV110/MV110W/MV145/MV255	13
MI-001 OIML R49 CLASS2: MV110/MV110W/MV145/MV255	13
MI-001 OIML R49 CLASS1: MV800	14
MI-001 OIML R49 CLASS 2: MV800	14
MI-004 CLASS1: MV110/MV110W /MV800	16
HOW TO ORDER	19

The manufacturer guarantees only English text available on our web site www.isoli.com

TECHNICAL DATA

OVERALL FEATURES

Nominal diameter	<input type="checkbox"/> DN 25 ÷ 2000
Minimum conductivity	<input type="checkbox"/> 5 µS/cm
Humidity Range	<input type="checkbox"/> 0÷100% (IP 67)
Accuracy	<input type="checkbox"/> See relevant converter data sheet
CE Certification	<input type="checkbox"/> Yes
PED	<input type="checkbox"/> Yes

STANDARD FEATURES

Body material	<input type="checkbox"/> Carbon steel painted
Nominal pressure	<input type="checkbox"/> 1600 kPa (4000 kPa up to DN 50)
Process connection	<input type="checkbox"/> Flanges std : UNI PN 16
Version – protection rating	<input type="checkbox"/> Compact IP67 (IP68 on request)
Flanges material	<input type="checkbox"/> Carbon steel
Lining material	<input type="checkbox"/> Polipropilene (max. PN 16) <input type="checkbox"/> Ebonite <input type="checkbox"/> PTFE (max PN 40) <input type="checkbox"/> Rilsan (max. PN 16)
Gasket material (ONLY for lining in Polypropylene)	<input type="checkbox"/> FPM
Liquid temperature	<input type="checkbox"/> 0°C ÷ 70°C with Rilsan lining <input type="checkbox"/> 0°C ÷ 60°C with PP lining <input type="checkbox"/> -5°C ÷ 80°C with ebonite lining <input type="checkbox"/> -20°C ÷ 100°C with PTFE lining in compact version
Vacuum resistance	<input type="checkbox"/> 20 Kpa (absolute) at 100 °C (60/80°C for PP/Ebonite)
Electrodes material	<input type="checkbox"/> Acciaio inox AISI 316 <input type="checkbox"/> Hastelloy <input type="checkbox"/> Platinum <input type="checkbox"/> Titanium <input type="checkbox"/> Tantalum

OPTIONAL FEATURES

(CHECK FOR MORE DETAILS 'HOW TO ORDER' ON LAST PAGE)

Body material	<input type="checkbox"/> Stainless steel AISI 304 or 316
Gaskets material (ONLY for lining in Polypropylene)	<input type="checkbox"/> EPDM
Nominal pressure	<input type="checkbox"/> Higher pressure rates available on request
Process connection	<input type="checkbox"/> Flanges: UNI, ANSI, DIN, JIS Others on request
Flanges material	<input type="checkbox"/> Stainless steel AISI 304 - AISI316
Liquid temperature	<input type="checkbox"/> -20°C ÷ 180°C* with PTFE lining in separate version: * sensors with working temperature higher than 110 ° C are classified according to PED guidelines (details on table in the next page).
Lining material	<input type="checkbox"/> On request
Electrodes material	<input type="checkbox"/> On request
Grounding electrode	<input type="checkbox"/> On request
Version – protection rating	<input type="checkbox"/> Separate version (max 20m) – IP 68 <input type="checkbox"/> Separate version (max 500 m), with preamplifier – IP 67 <input type="checkbox"/> Separate version (max 500 m), with preamplifier – IP 68
Certifications	<input type="checkbox"/> MI-001 (check table below) <input type="checkbox"/> MI-004 (check table below)

97/23/CE PED DIRECTIVE

Here below the tables of products subject to Directive 97/23/EC for MS2500

The tables show which category of PED is applicable according to the water operating temperature (TAB A T <110 ° C TAB B T > = 110 ° C), sensor's DN and its nominal pressure.

TAB. A PED DIRECTIVE FOR WATER WITH TEMPERATURE <110°C ALL LINING : PP, EBONITE, PTFE				
DN	NOMINAL PRESSURE (PN)			
	10	16	25	40
25	USARE PN 40			
32	USARE PN 40			
40	USARE PN 40			
50		E		E
65		E		E
80	USARE PN 16	E	USARE PN 40	E
100		E		E
125		E		E
150		E		E
200	E	E	E	E
250	I	I	I	I
300	I	I	I	I
350	I	I	I	I
400	I	I	I	I
450	I	I	I	I
500	I	I	I	I
600	I	I	I	I
700	I	I	I	I
800	I	I	I	I
900	I	I	I	I
1000	I	I	I	I
1200	I	I	I	I
1300	I	I	I	I
1400	I	I	I	I
1500	I	I	I	I
1600	I	I	I	I
1700	I	I	I	I
1800	I	I	I	I
2000	I	I	I	I
2400	I	I	I	I

TAB. B PED DIRECTIVE FOR WATER WITH TEMPERATURE >=110°C ONLY PTFE LINING				
DN	NOMINAL PRESSURE (PN)			
	10	16	25	40
25	USARE PN 40			
32	USARE PN 40			
40	USARE PN 40			
50		I		II
65		I		II
80	USARE PN 16	I	USARE PN 40	II
100		I		II
125		I		II
150		I		II
200	I	I	II	II
250	I	II	II	II
300	I	II	III	III
350	I	III	III	III
400	II	III	III	III
450	II	III	III	III
500	II	III	III	III

LEGENDA	
E	EXCLUDED FROM DIRECTIVE
I	PED CAT. I
II	PED CAT. II
III	PED CAT. III

For each product is released a declaration of conformity, identified by the instrument's serial number

OVERALL DIMENSIONS

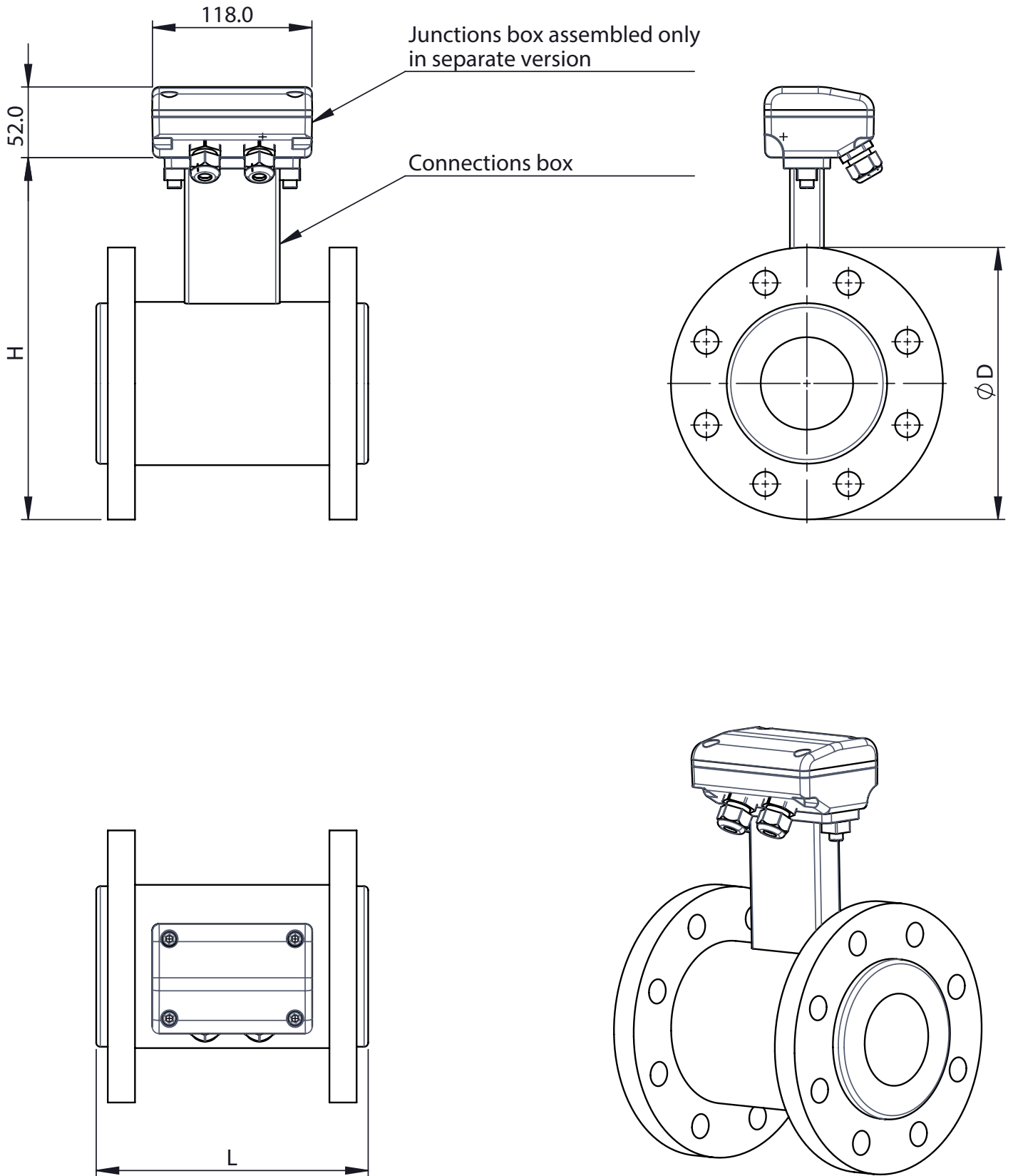

The manufacturer guarantees only English text available on our web site www.isoil.com

MS 2500 PN 10/64 - ANSI 150/300 OVERALL DIMENSIONS

DIMENSIONS mm (inches)			PN						
			PN 10	PN 16	PN 25	PN 40	PN 64	ANSI 150	ANSI 300
DN	25 (1")	L	200 (7.87)	200 (7.87)	200 (7.87)	200 (7.87)	200 (7.87)	200 (7.87)	200 (7.87)
		H	185 (7.28)	185 (7.28)	185 (7.28)	185 (7.28)	198 (7.80)	181 (7.13)	190 (7.48)
		D	115 (4.53)	115 (4.53)	115 (4.53)	115 (4.53)	140 (5.51)	108 (4.25)	124 (4.88)
	32 (1"1/4)	L	200 (7.87)	200 (7.87)	200 (7.87)	200 (7.87)	200 (7.87)	200 (7.87)	200 (7.87)
		H	203 (8)	203 (8)	203 (8)	203 (8)	209 (8.23)	192 (7.56)	199 (7.83)
		D	140 (5.51)	140 (5.51)	140 (5.51)	140 (5.51)	155 (6.10)	118 (4.65)	133 (5.24)
	40 (1"1/2)	L	200 (7.87)	200 (7.87)	200 (7.87)	200 (7.87)	200 (7.87)	200 (7.87)	200 (7.87)
		H	213 (8.39)	213 (8.39)	213 (8.39)	213 (8.39)	220 (8.66)	207 (8.15)	221 (8.7)
		D	150 (5.90)	150 (5.90)	150 (5.90)	150 (5.90)	170 (6.69)	127 (5)	156 (6.14)
	50 (2")	L	200 (7.87)	200 (7.87)	200 (7.87)	200 (7.87)	200 (7.87)	200 (7.87)	200 (7.87)
		H	228 (8.98)	228 (8.98)	228 (8.98)	228 (8.98)	233 (9.17)	222 (8.74)	228 (8.98)
		D	165 (6.50)	165 (6.50)	165 (6.50)	165 (6.50)	180 (7.09)	152 (5.98)	165 (6.5)
	65 (2"1/2)	L	200 (7.87)	200 (7.87)	200 (7.87)	200 (7.87)	200 (7.87)	200 (7.87)	200 (7.87)
		H	248 (9.76)	248 (9.76)	248 (9.76)	248 (9.76)	257 (10.12)	245 (9.65)	251 (9.88)
		D	185 (7.28)	185 (7.28)	185 (7.28)	185 (7.28)	205 (8.07)	178 (7.01)	191 (7.52)
	80 (3")	L	200 (7.87)	200 (7.87)	200 (7.87)	200 (7.87)	200 (7.87)	200 (7.87)	200 (7.87)
		H	263 (10.35)	263 (10.35)	263 (10.35)	263 (10.35)	267 (10.51)	259 (10.2)	268 (10.55)
		D	200 (7.87)	200 (7.87)	200 (7.87)	200 (7.87)	215 (8.46)	191 (7.52)	210 (8.27)
	100 (4")	L	250 (9.84)	250 (9.84)	250 (9.84)	250 (9.84)	250 (9.84)	250 (9.84)	250 (9.84)
		H	283 (11.14)	283 (11.14)	294 (11.57)	294 (11.57)	297 (11.69)	288 (11.34)	300 (11.81)
		D	220 (8.66)	220 (8.66)	235 (9.25)	235 (9.25)	250 (9.84)	229 (9.02)	254 (10)
	125 (5")	L	250 (9.84)	250 (9.84)	250 (9.84)	250 (9.84)	250 (9.84)	250 (9.84)	250 (9.84)
		H	313 (12.32)	313 (12.32)	325 (12.80)	325 (12.80)	330 (13)	315 (12.4)	328 (12.91)
		D	250 (9.84)	250 (9.84)	270 (10.63)	270 (10.63)	295 (11.61)	254 (10)	279 (10.98)
	150 (6")	L	300 (11.81)	300 (11.81)	300 (11.81)	300 (11.81)	300 (11.81)	300 (11.81)	300 (11.81)
		H	344 (13.54)	344 (13.54)	355 (13.98)	355 (13.98)	377 (14.84)	341 (13.43)	360 (14.17)
		D	285 (11.22)	285 (11.22)	300 (11.81)	300 (11.81)	345 (13.58)	279 (10.98)	318 (12.52)
	200 (8")	L	350 (13.78)	350 (13.78)	350 (13.78)	350 (13.78)	350 (13.78)	350 (13.78)	350 (13.78)
		H	399 (15.71)	399 (15.71)	415 (16.34)	425 (16.73)	435 (17.13)	401 (15.79)	420 (16.54)
		D	340 (13.39)	340 (13.39)	360 (14.17)	375 (14.76)	415 (16.34)	343 (13.5)	381 (15)
	250 (10)	L	450 (17.72)	450 (17.72)	450 (17.72)	450 (17.72)	450 (17.72)	450 (17.72)	450 (17.72)
		H	454 (17.87)	460 (18.11)	475 (18.7)	493 (19.41)	491 (19.33)	461 (18.15)	480 (18.9)
		D	395 (15.55)	405 (15.94)	425 (16.73)	450 (17.72)	470 (18.5)	406 (15.98)	445 (17.52)
	300 (12")	L	500 (19.69)	500 (19.69)	500 (19.69)	500 (19.69)	500 (19.69)	500 (19.69)	500 (19.69)
		H	504 (19.84)	515 (20.28)	535 (21.06)	558 (21.97)	545 (21.46)	527 (20.75)	546 (21.5)
		D	445 (17.52)	460 (18.11)	485 (19.09)	515 (20.28)	530 (20.87)	483 (19.02)	521 (20.51)
	350 (14")	L	550 (21.65)	550 (21.65)	550 (21.65)	550 (21.65)	550 (21.65)	550 (21.65)	550 (21.65)
		H	564 (22.2)	575 (22.64)	598 (23.54)	619 (24.37)	603 (23.74)	582 (22.91)	607 (23.9)
		D	505 (19.88)	520 (20.47)	555 (21.85)	580 (22.83)	600 (23.62)	533 (20.98)	584 (22.99)
	400 (16")	L	600 (23.62)	600 (23.62)	600 (23.62)	600 (23.62)	600 (23.62)	600 (23.62)	600 (23.62)
		H	620 (24.41)	630 (24.8)	659 (25.94)	695 (27.36)	670 (26.38)	639 (25.16)	664 (26.14)
		D	565 (22.24)	580 (22.83)	62 (2.44)	660 (25.98)	670 (26.38)	597 (23.5)	648 (25.51)
	450 (18")	L	600 (23.62)	600 (23.62)	600 (23.62)	600 (23.62)		600 (23.62)	600 (23.62)
		H	670 (26.38)	690 (27.17)	709 (27.91)	720 (28.35)		688 (27.09)	726 (28.58)
		D	615 (24.21)	640 (25.2)	670 (26.38)	685 (26.97)		635 (25)	711 (27.99)
	500 (20")	L	600 (23.62)	600 (23.62)	600 (23.62)	600 (23.62)		600 (23.62)	600 (23.62)
		H	725 (28.54)	758 (29.84)	769 (30.28)	784 (30.87)		751 (29.57)	770 (30.31)
		D	670 (26.38)	715 (28.15)	730 (28.74)	755 (29.72)		699 (27.52)	775 (30.51)

The manufacturer guarantees only English text available on our web site www.isoil.com

MS 2500 PN 10/64 - ANSI 150/300 OVERALL DIMENSIONS

DIMENSIONS mm (inches)		PN							
		PN 10	PN 16	PN 25	PN 40	PN 64	ANSI 150	ANSI 300	
DN	600 (24")	L	600 (23.62)	600 (23.62)	600 (23.62)	600 (23.62)		600 (23.62)	600 (23.62)
		H	830 (32.68)	879 (34.61)	880 (34.65)	911 (35.87)		866 (34.09)	916 (36.06)
		D	780 (30.71)	840 (33.07)	845 (33.27)	890 (35.04)		813 (32.01)	914 (35.98)
	650 (26")	L						650 (25.59)	650 (25.59)
		H						921 (36.26)	1002 (39.45)
		D						870 (34.25)	972 (38.27)
	700 (28")	L	700 (27.56)	700 (27.56)	700 (27.56)	700 (27.56)		700 (27.56)	
		H	925 (36.41)	949 (37.36)	989 (38.94)	1016 (40)		1016 (40)	
		D	895 (35.24)	910 (35.83)	960 (37.8)	995 (39.17)		927,1 (36,5)	
	750 (30")	L						750 (29.53)	750 (29.53)
		H						1032 (40.63)	1121 (44.13)
		D						984 (38.74)	1092 (42.99)
	800 (32")	L	800 (31.5)	800 (31.5)	800 (31.5)	800 (31.5)		800 (31.5)	
		H	1058 (41.65)	1060 (41.73)	1106 (43.54)	1149 (45.24)		1149 (45.24)	
		D	1015 (39.96)	1025 (40.35)	1085 (42.72)	1114 (43.86)		1060,5 (47,15)	
	850 (34")	L						850 (33.46)	850 (33.46)
		H						1149 (45.24)	1230 (48.43)
		D						1111 (43.74)	1207 (47.52)
	900 (36")	L	900 (35.43)	900 (35.43)	900 (35.43)	900 (35.43)		900 (35.43)	900 (35.43)
		H	1158 (45.59)	1160 (45.67)	1206 (47.48)	1259 (49.57)		1206 (47.48)	1292 (50.87)
		D	1115 (43.9)	1125 (44.29)	1185 (46.65)	1250 (49.21)		1168 (45.98)	1270 (50)
	1000 (40")	L	1000 (39.37)	1000 (39.37)	1000 (39.37)	1000 (39.37)		1000 (39.37)	1000 (39.37)
		H	1269 (49.96)	1284 (50.55)	1329 (52.32)	1369 (53.9)		1381 (54.37)	1467 (57.76)
		D	1230 (48.43)	1255 (49.41)	1320 (51.97)	1360 (53.54)		1346 (52.99)	1448 (57.01)
1050 (42")	L						1050 (41.3)		
	H						1355.0 (54.00)		
	D						1346.2 (53.00)		
1100 (44")	L						1100 (43.3)		
	H						1428 (56.25)		
	D						1403.4 (55.25)		
1200 (48")	L						1200 (47.24)		
	H						1530 (60.50)		
	D						1511.3 (59.50)		
1800 (72")	L						1800 (72.00)		
	H						1381 (54.37)		
	D						2197 (86.50)		

The manufacturer guarantees only English text available on our web site www.isoil.com

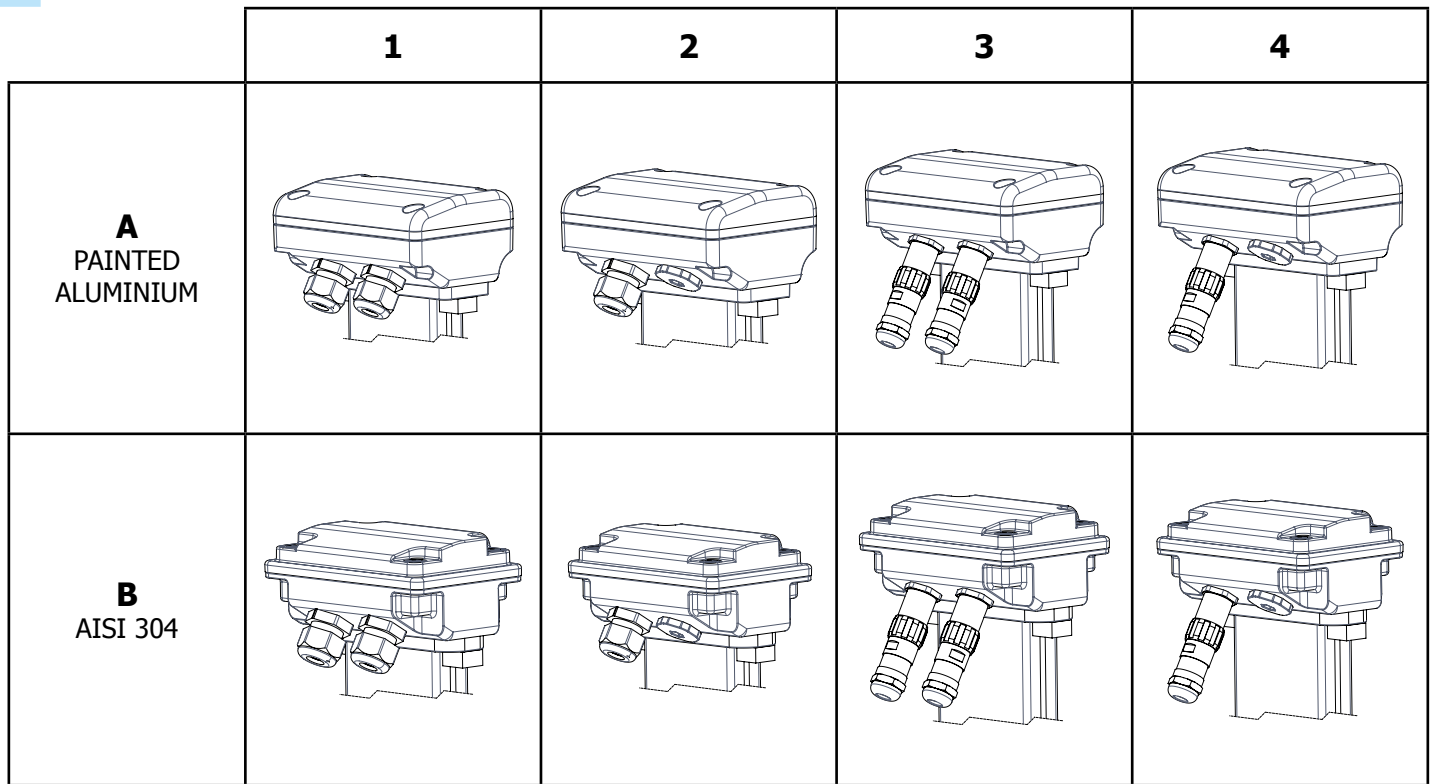

The manufacturer guarantees only English text available on our web site www.isoli.com

PRICE LIST OPTIONS	JUNCTION BOX TYPE (surface finish)
A	Without junction box, converter connected on the connections box
B	A-1 A-2 only for ML110
G	A-4
F	A-3
N	A-2 with preamplifier
Q	A-4 with preamplifier
U	B-1 (raw) B-2 only for ML110 (raw)
S	B-4 (raw)
T	B-3 (raw)
P	B-2 with preamplifier (raw)
R	B-4 with preamplifier (raw)
K	B-1 (polished) B-2 only for ML110 (polished)
Y	B-4 (polished)
W	B-3 (polished)
V	B-2 with preamplifier (polished)
J	B-4 con preamplificatore (finitura lucidata)

SEPARATE VERSION

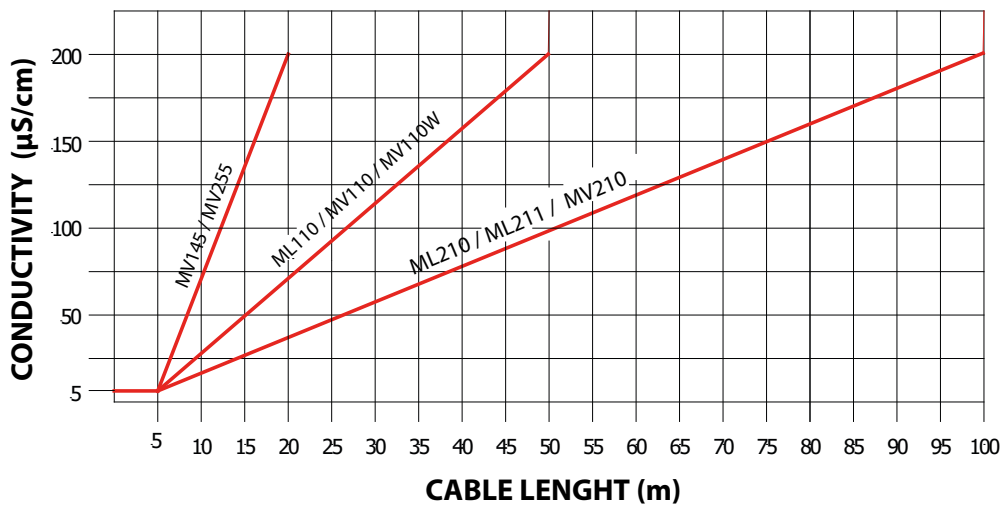
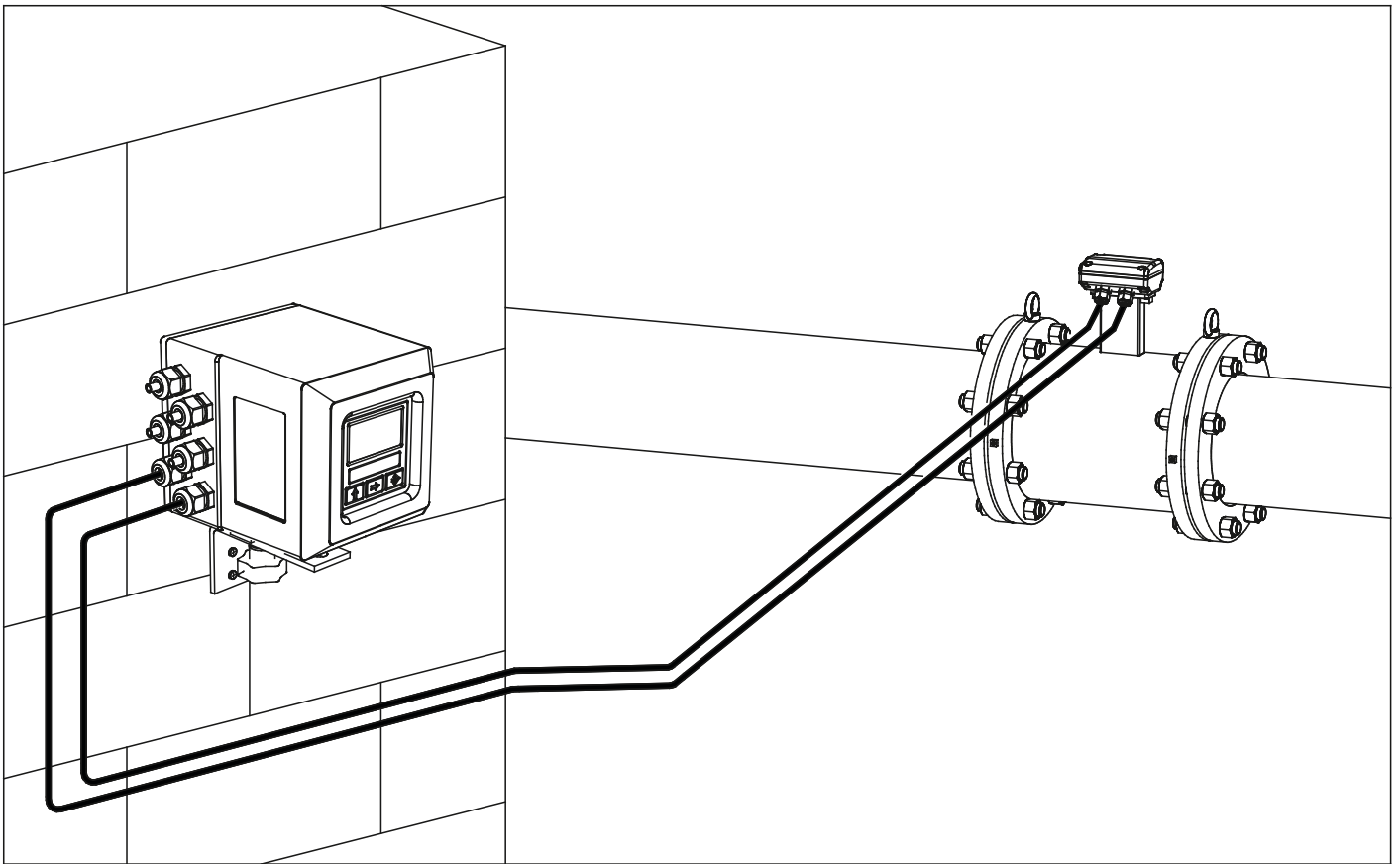

Notes:

- It is recommended to install the connection cables away from, or protect against sources of electromagnetic noise.
- The minimum conductivity of the liquid medium to ensure correct functionality of the empty pipe detection is 20 µS/cm

INSTALLATION RECOMMENDATIONS

In vertical installations an ascending flow is preferable. For vertical installations with descending flow direction contact the manufacturer

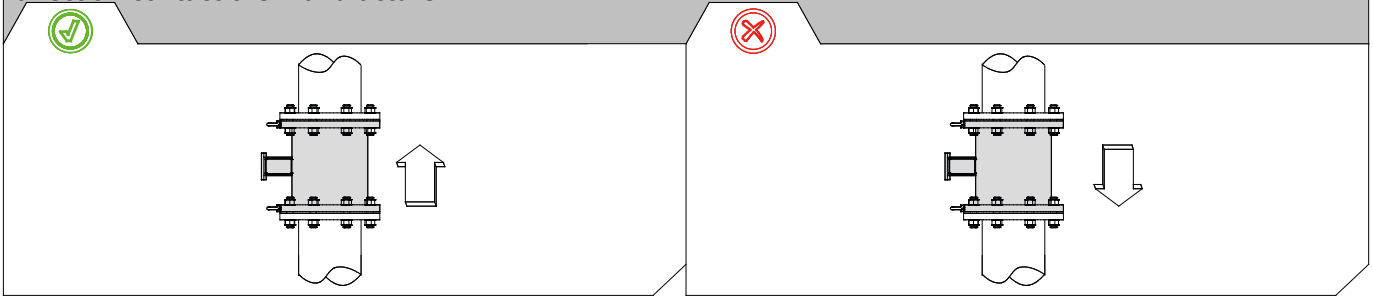

For installations in long pipe lines, please use anti vibration joints

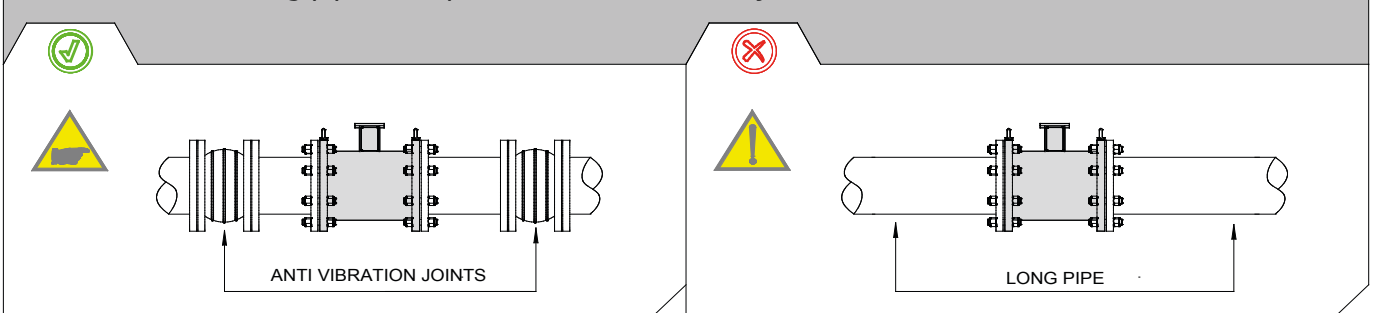

Avoid a partially empty pipe, during operation the pipe must be either completely full of liquid or completely empty

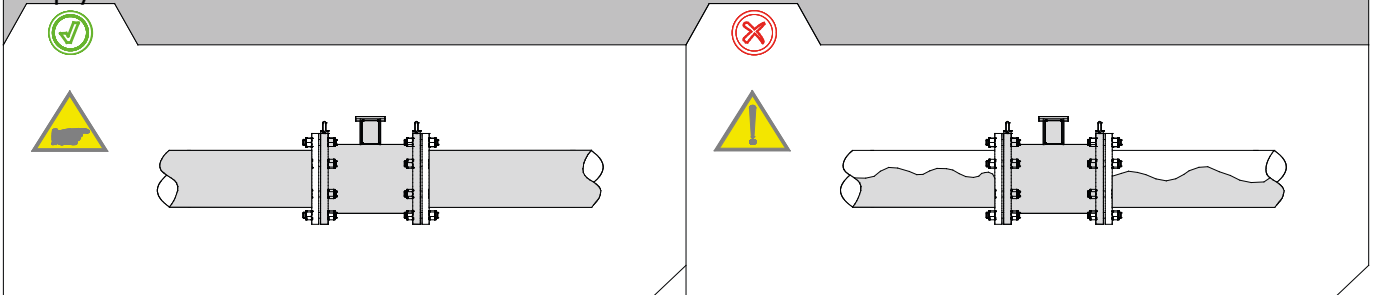

Install the sensor away from bends and hydraulic accessories

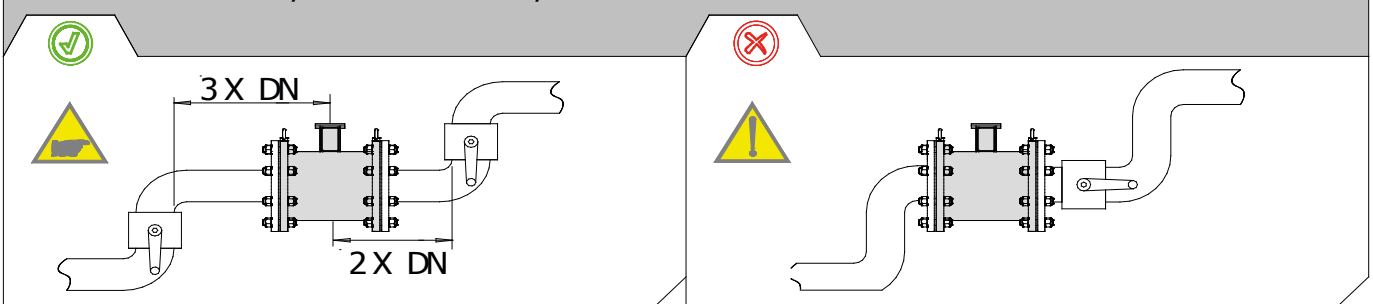

Avoid positioning flanges by tightening the nuts.

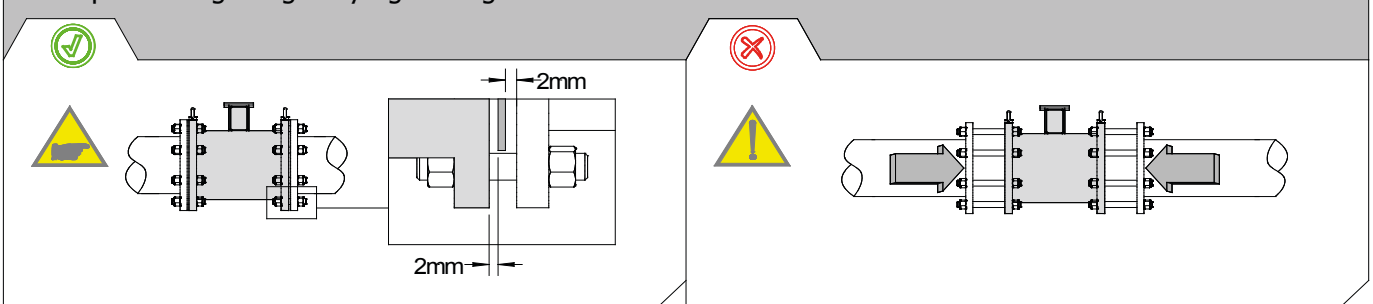

RECOMMENDED INSTALLATION PROCEDURE

Sensors weighing more than 20Kg are equipped of appropriate eyebolts to lift the sensor according to the drawing above.

The eyebolts support ONLY the weight of the meter.

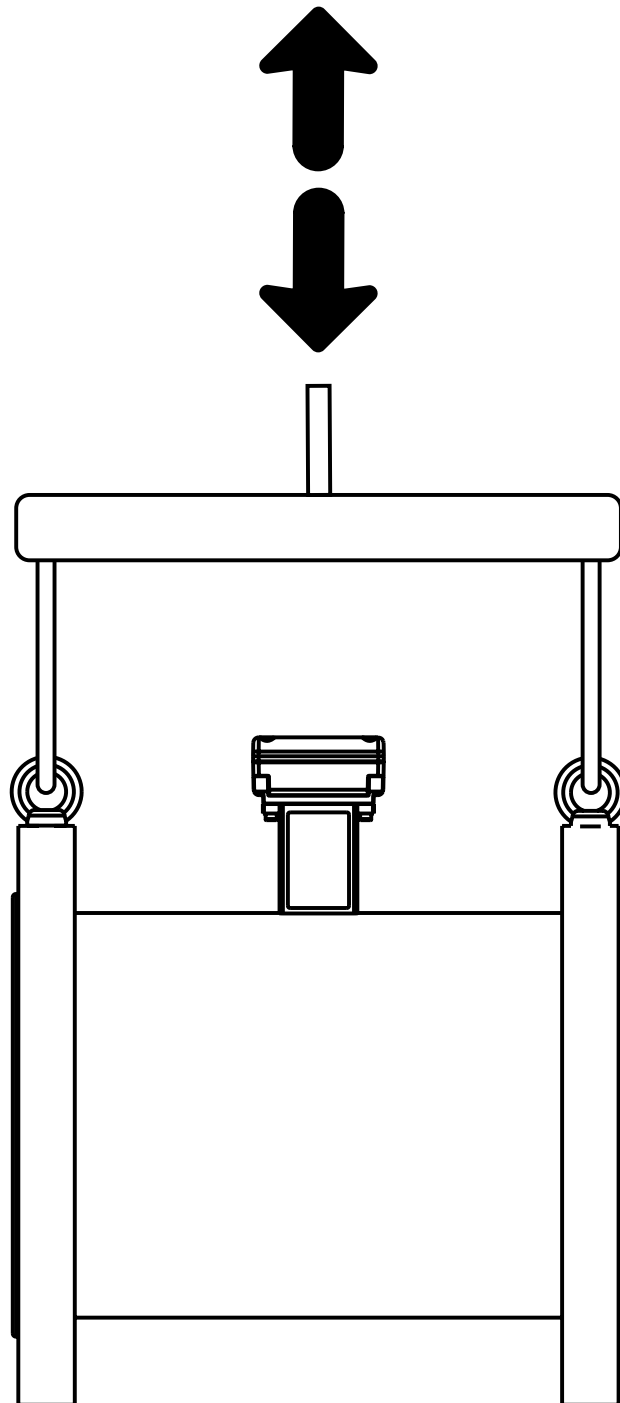

SENSOR GROUNDING

METALLIC PIPE

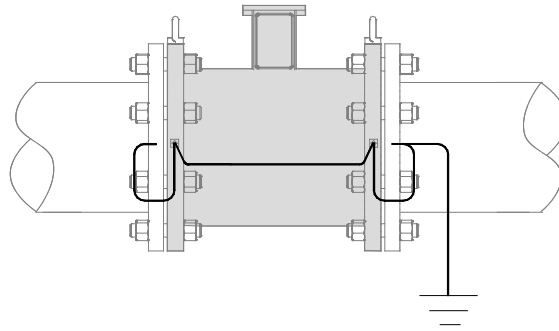

INSULATED PIPE

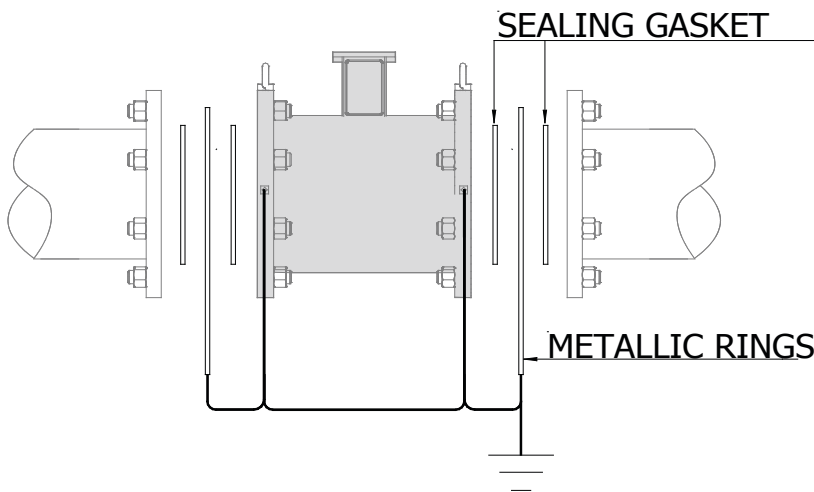

If the sensor has to be installed in a pipe made of an insulating material, the following are necessary:

Inserting two metallic rings between the sensor flanges and the pipe line counter flanges

or:

Using a sensor with the additional grounding electrode

PIPE WITH CATHODIC PROTECTION

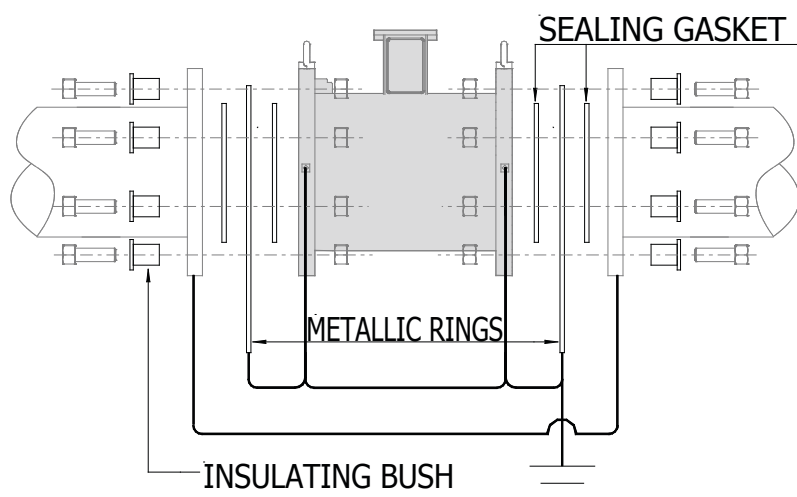

If the sensor has to be installed in the pipe with cathodic protection, the following are necessary:

using insulating bushes to isolate the bolts

Metallic grounding rings should be provided to ground the liquid using insulating gasket between the rings

PRESSURE LOSS CALCULATION (CONES 8° ANGLES)

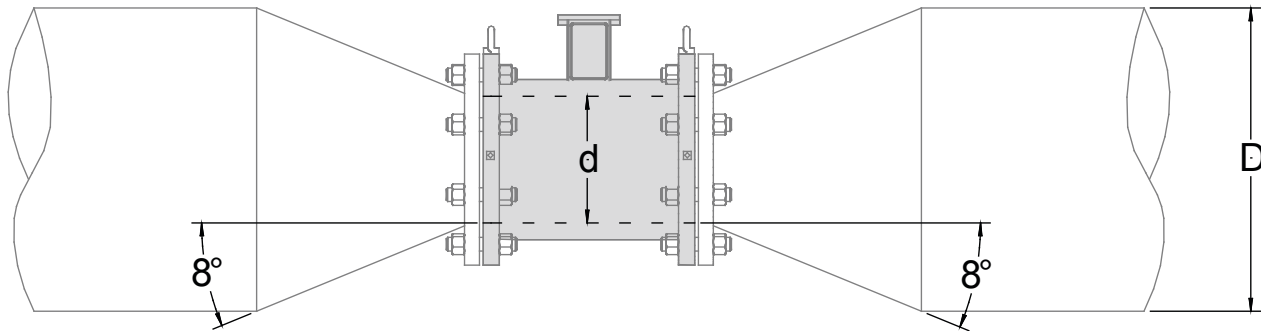

$$\Delta p = \left[0.10 + 0.20 \left(\left(\frac{d}{D} \right)^{-2} - 1 \right) \left(\frac{d}{D} \right)^4 \right] \left(\rho \frac{u^2}{2} \right)$$

Were:

- Δp = Pressure loss in [Pa]
- ρ = Fluid density [kg/m³] typical value $\rho = 1000$ [kg/m³]
- d = sensor diameter [m]
- D = pipe diameter (greater than sensor diameter) [m]
- u = Mean flow velocity in sensor diameter [m/s]

Calculation examples Δp [mbar]								
d/D \ u	1 [m/s]	2 [m/s]	3 [m/s]	4 [m/s]	5 [m/s]	6 [m/s]	7 [m/s]	8 [m/s]
0.5	1.1	4.3	9.6	17	26.6	38.3	52.1	68
0.6	0.9	3.6	8.2	14.6	22.7	32.7	44.6	58.2
0.7	0.8	3	6.8	12.2	19	27.4	37.2	48.6
0.8	0.6	2.5	5.7	10.1	15.7	22.7	30.9	40.3
0.9	0.5	2.1	4.8	8.6	13.4	19.3	26.3	34.3

Notes:

- $\rho = 1000$ [kg/m³] as goodness approximation of water density in common use.
- Inner diameter of sensor is used for d , express in meters.
- Indeed pressure loss equation is dimensionally correct in [Pa]. The equation results in table are show in [mbar].

MI-001 OIML R49 CLASS1: MV110/MV110W/MV145/MV255

The MS2500 sensor's diameters listed below, coupled with MV110/MV110W/MV145/MV255, are certified according to European Directive 2014/32/EU category MI-001 (OIML R49)

SENSOR SIZE	mm	25	32	40	50	65	80	100	125	150	200
	inch	1	1 ¼	1 ½	2	2 ½	3	4	5	6	8
Q1	m ³ /h	0.160	0.250	0.400	0.630	1.000	1.600	2.500	4.000	6.300	10.000
Q2	m ³ /h	0.256	0.400	0.640	1.008	1.600	2.560	4.000	6.400	10.080	16.000
Q3	m³/h	16	25	40	63	100	160	250	400	630	1000
R	Q3/Q1	100									

SENSOR SIZE	mm	250	300	350	400	450	500	600	700	800	900	1000
	inch	10	12	14	16	18	20	24	28	32	36	42
Q1	m ³ /h	20.000	31.25	31.25	50.00	50.00	78.75	125.0	125.0	200.0	200.0	312.5
Q2	m ³ /h	32.000	50.00	50.00	80.00	80.00	126.0	200.0	200.0	320.0	320.0	500.0
Q3	m³/h	1600***	2500**	2500**	4000**	4000**	6300	10000	10000	16000*	16000*	25000*
R	Q3/Q1	80										

MI-001 OIML R49 CLASS2: MV110/MV110W/MV145/MV255

The MS2500 sensor's diameters listed below, coupled with MV110/MV110W/MV145/MV255, are certified according to European Directive 2014/32/EU category MI-001 (OIML R49)

SENSOR SIZE	mm	25	32	40	50	65	80	100	125	150	200
	inch	1	1 ¼	1 ½	2	2 ½	3	4	5	6	8
Q1	m ³ /h	0.100	0.160	0.250	0.390	0.630	1.000	1.560	2.500	3.940	6.250
Q2	m ³ /h	0.160	0.250	0.400	0.630	1.000	1.600	2.500	4.000	6.300	10.000
Q3	m³/h	16	25	40	63	100	160	250	400	630	1000
R	Q3/Q1	160									

SENSOR SIZE	mm	250	300	350	400	450	500	600	700	800	900	1000
	inch	10	12	14	16	18	20	24	28	32	36	42
Q1	m ³ /h	16.00	25.00	25.00	40.00	40.00	63.00	100.0	100.0	160.0	160.0	250.0
Q2	m ³ /h	25.60	40.00	40.00	64.00	64.00	100.8	160.0	160.0	256.0	256.0	400.0
Q3	m³/h	1600***	2500**	2500**	4000**	4000**	6300	10000	10000	16000*	16000*	25000*
R	Q3/Q1	100										

(*) : Calibration flowrate 14000 m³/h - as for max rig flowrate L8

(**) : Calibration flowrate 1400 m³/h - as for max test rig flowrate L7

(***) Calibration flowrate 1100 m³/h - as for max test rig flowrate L6

MI-001 OIML R49 CLASS1: MV800

The MS2500 sensor's diameters listed below, coupled with MV800, are certified according to European Directive 2014/32/EU category MI-001 (OIML R49)

SENSOR SIZE	mm	25	32	40	50	65	80	100	125	150	200
	inch	1	1 ¼	1 ½	2	2 ½	3	4	5	6	8
Q1	m ³ /h	0.160	0.250	0.400	0.630	1.000	1.600	2.500	4.000	6.300	10.000
Q2	m ³ /h	0.256	0.400	0.640	1.008	1.600	2.560	4.000	6.400	10.080	16.000
Q3	m³/h	16	25	40	63	100	160	250	400	630	630
R	Q3/Q1	100									63

MI-001 OIML R49 CLASS 2: MV800

The MS2500 sensor's diameters listed below, coupled with MV800, are certified according to European Directive 2014/32/EU category MI-001 (OIML R49)

SENSOR SIZE	mm	25	32	40	50	65	80	100	125	150	200
	inch	1	1 ¼	1 ½	2	2 ½	3	4	5	6	8
Q1	m ³ /h	0.100	0.156	0.250	0.394	0.625	1.000	1.563	2.500	3.938	7.880
Q2	m ³ /h	0.160	0.250	0.400	0.630	1.000	1.600	2.500	4.000	6.300	12.60
Q3	m³/h	16	25	40	63	100	160	250	400	630	630
R	Q3/Q1	160									80

SENSOR SIZE	mm	250
	inch	10
Q1	m ³ /h	15.75
Q2	m ³ /h	25.200
Q3	m³/h	630
R	Q3/Q1	40

MPE - MI 001 - OIML R49 ACCURACYCLASS 1
(OIML R 49-1:2013 (E) - ISO4064-1:2017)

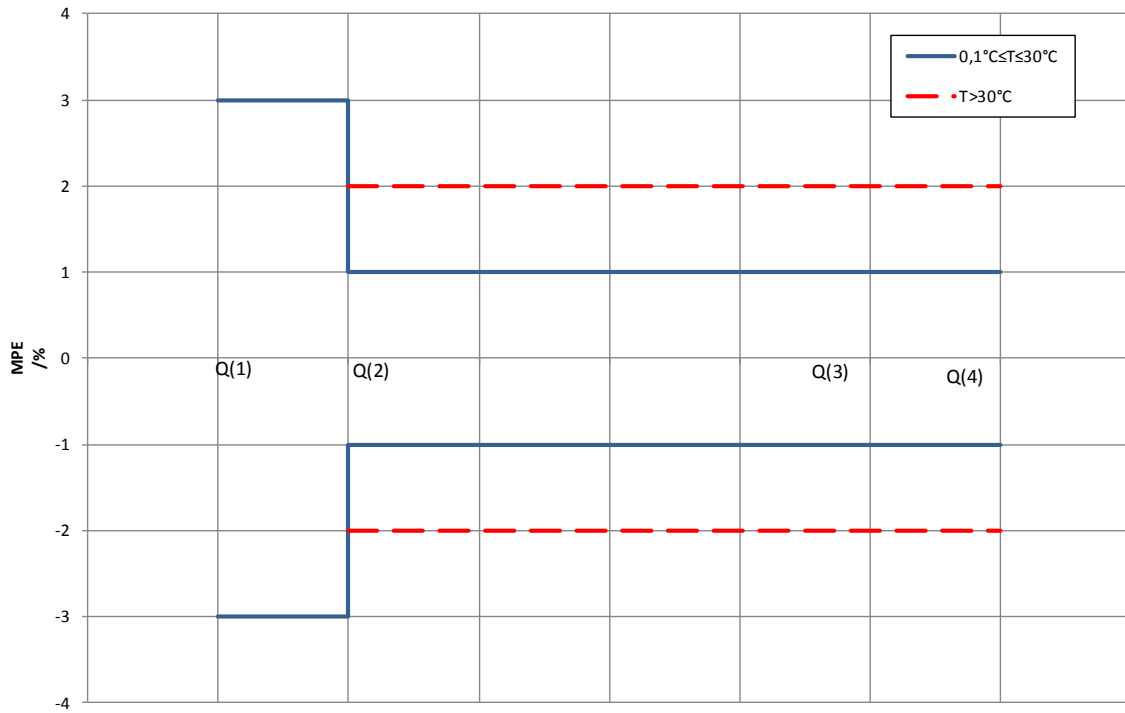

MPE - MI 001 - OIML R49 ACCURACYCLASS 2
(OIML R 49-1:2013 (E) - ISO4064-1:2017)

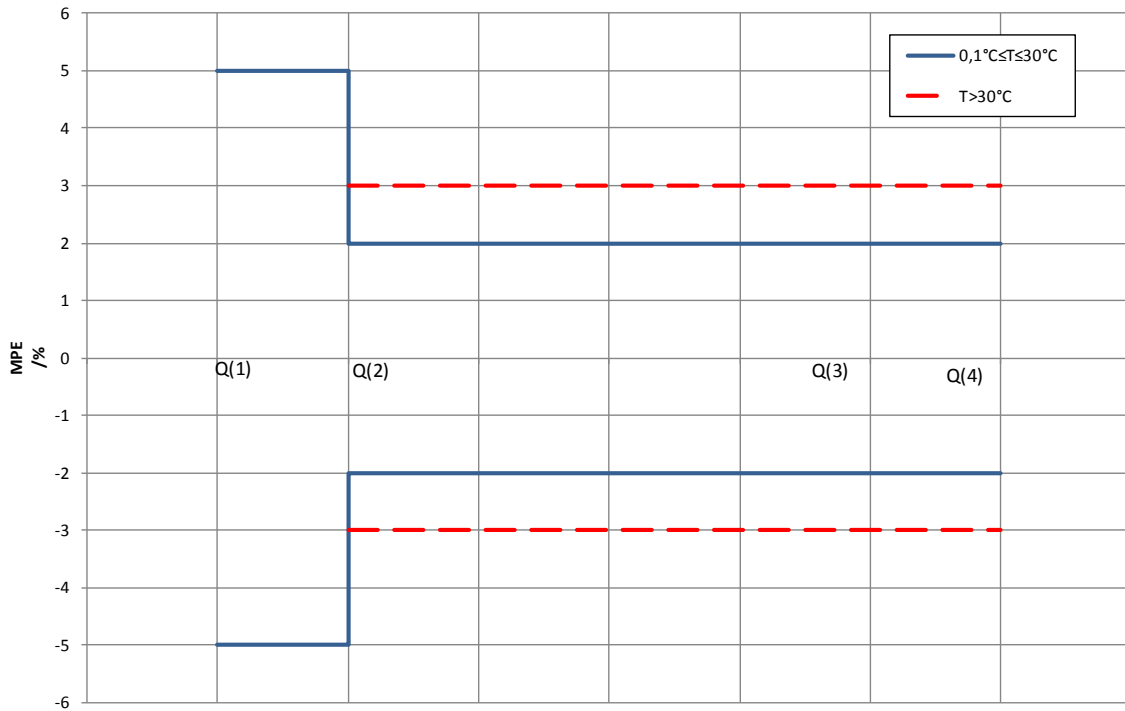

MI-004 CLASS1: MV110/MV110W /MV800

The MS2500 sensor's diameters listed below, coupled with MV110 / MV110W / MV800, are certified according to European Directive 2014/32/EU category MI-004

SENSOR SIZE	mm	25	32	40	50	65	80	100	125	150	200	250	300	350	400
	inch	1	1 ¼	1 ½	2	2 ½	3	4	5	6	8	10	12	14	16
q _i	m ³ /h	0.16	0.25	0.40	0.63	1.0	1.6	2.5	4.0	6.3	10	16	25	25	40
0,1 q _p	m ³ /h	1.6	2.5	4.0	6.3	10	16	25	40	63	100	160	250	250	400
q _p (10m/s)	m ³ /h	16	25	40	63	100	160	250	400	630	1000	1600*	2500*	2500*	4000*
q _s	m ³ /h	16	25	40	63	100	160	250	400	630	1000	1600	2500	2500	4000
q_p/q_i	100														

SENSOR SIZE	mm	25	32	40	50	65	80	100	125	150	200	250	300	350	400
	inch	1	1 ¼	1 ½	2	2 ½	3	4	5	6	8	10	12	14	16
q _i	m ³ /h	0.20	0.32	0.50	0.80	1.26	2.0	3.2	5.0	8.0	12.6	20	32	50	50
0,1 q _p	m ³ /h	1.0	1.6	2.5	4.0	6.3	10	16	25	40	63	100	160	250	250
q _p (5m/s)	m ³ /h	10	16	25	40	63	100	160	250	400	630	1000	1600*	2500*	2500*
q _s	m ³ /h	16	25	40	63	100	160	250	400	630	1000	1600	2500	2500	4000
q_p/q_i	50														

SENSOR SIZE	mm	25	32	40	50	65	80	100	125	150	200	250	300	350	400
	inch	1	1 ¼	1 ½	2	2 ½	3	4	5	6	8	10	12	14	16
q _i	m ³ /h	0.40	0.64	1.00	1.60	2.52	4.00	6.40	10.0	16.0	25.2	40.0	64.0	100	100
0,1 q _p	m ³ /h	1.0	1.6	2.5	4.0	6.3	10.0	16.0	25.0	40.0	63.0	100	160	250	250
q _p (2,5m/s)	m ³ /h	10	16	25	40	63	100	160	250	400	630	1000	1600*	2500*	2500*
q _s	m ³ /h	16	25	40	63	100	160	250	400	630	1000	1600	2500	2500	4000
q_p/q_i	25														

SENSOR SIZE	mm	25	32	40	50	65	80	100	125	150	200	250	300	350	400
	inch	1	1 ¼	1 ½	2	2 ½	3	4	5	6	8	10	12	14	16
q _i	m ³ /h	1.0	1.6	2.5	4.0	6.3	10.0	16.0	25.0	40.0	63.0	100	160	250	250
0,1 q _p	m ³ /h	1.0	1.6	2.5	4.0	6.3	10.0	16.0	25.0	40.0	63.0	100	160	250	250
q _p (1,0m/s)	m ³ /h	10	16	25	40	63	100	160	250	400	630	1000	1600*	2500*	2500*
q _s	m ³ /h	16	25	40	63	100	160	250	400	630	1000	1600	2500	2500	4000
q_p/q_i	10														

(*) : Reduced flowrates to the test rig limits

MI 004 - MPE - ACCURACY CLASS 1
(UNI EN 1434-1:2016)

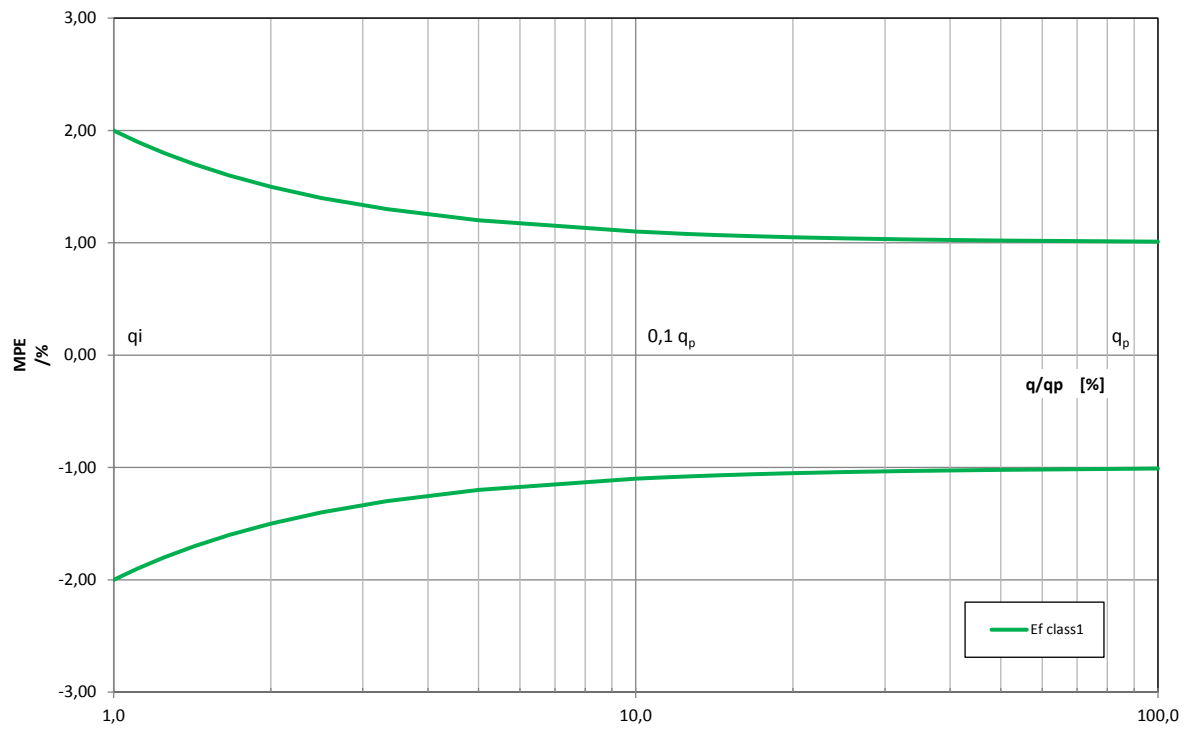

The manufacturer guarantees only English text available on our web site www.isoil.com

HOW TO ORDER

MS 2500	
code	Nominal Diameter / Lining / Liquid temperature / Measuring range
P25	DN25 (1"), P.P. lining, liquid maximum temperature 60 °C measuring range 0...0,72/0...18 m3/h
T25	DN25 (1"), PTFE lining, liquid maximum temperature 110 °C measuring range 0...0,72/0...18 m3/h
HT25	DN25 (1"), PFA lining, liquid maximum temperature 180 °C measuring range 0...0,72/0...18 m3/h
P32	DN32 (1 1/4"), P.P. lining, liquid maximum temperature 60 °C measuring range 0...1,16/0...29 m3/h
T32	DN32 (1 1/4"), PTFE lining, liquid maximum temperature 110 °C measuring range 0...1,16/0...29 m3/h
HT32	DN32 (1 1/4"), PFA lining, liquid maximum temperature 180 °C measuring range 0...1,16/0...29 m3/h
P40	DN40 (1 1/2"), P.P. lining, liquid maximum temperature 60 °C measuring range 0...1,8/0...45 m3/h
T40	DN40 (1 1/2"), PTFE lining, liquid maximum temperature 110 °C measuring range 0...1,8/0...45 m3/h
HT40	DN40 (1 1/2"), PFA lining, liquid maximum temperature 180 °C measuring range 0...1,8/0...45 m3/h
P50	DN50 (2"), P.P. lining, liquid maximum temperature 60 °C measuring range 0...2,88/0...72 m3/h
T50	DN50 (2"), PTFE lining, liquid maximum temperature 110 °C measuring range 0...2,88/0...72 m3/h
HT50	DN50 (2"), PFA lining, liquid maximum temperature 180 °C measuring range 0...2,88/0...72 m3/h
R50	DN50 (2"), RILSAN lining, liquid maximum temperature 70 °C measuring range 0...2,88/0...72 m3/h
P65	DN65 (2 1/2"), P.P. lining, liquid maximum temperature 60 °C measuring range 0...4,8/0...120 m3/h
T65	DN65 (2 1/2"), PTFE lining, liquid maximum temperature 110 °C measuring range 0...4,8/0...120 m3/h
HT65	DN65 (2 1/2"), PFA lining, liquid maximum temperature 180 °C measuring range 0...4,8/0...120 m3/h
R65	DN65 (2 1/2"), RILSAN lining, liquid maximum temperature 70 °C measuring range 0...4,8/0...120 m3/h
P80	DN80 (3"), P.P. lining, liquid maximum temperature 60 °C measuring range 0...7,2/0...180 m3/h
T80	DN80 (3"), PTFE lining, liquid maximum temperature 110 °C measuring range 0...7,2/0...180 m3/h
HT80	DN80 (3"), PFA lining, liquid maximum temperature 180 °C measuring range 0...7,2/0...180 m3/h
R80	DN80 (3"), RILSAN lining, liquid maximum temperature 70 °C measuring range 0...7,2/0...180 m3/h
P100	DN100 (4"), P.P. lining, liquid maximum temperature 60 °C measuring range 0...11,2/0...280 m3/h
T100	DN100 (4"), PTFE lining, liquid maximum temperature 110 °C measuring range 0...11,2/0...280 m3/h
HT100	DN100 (4"), PFA lining, liquid maximum temperature 180 °C measuring range 0...11,2/0...280 m3/h
R100	DN100 (4"), RILSAN lining, liquid maximum temperature 70 °C measuring range 0...11,2/0...280 m3/h
P125	DN125 (5"), P.P. lining, liquid maximum temperature 60 °C measuring range 0...18/0...450 m3/h
T125	DN125 (5"), PTFE lining, liquid maximum temperature 110 °C measuring range 0...18/0...450 m3/h
HT125	DN125 (5"), PFA lining, liquid maximum temperature 180 °C measuring range 0...18/0...450 m3/h
R125	DN125 (5"), RILSAN lining, liquid maximum temperature 70 °C measuring range 0...18/0...450 m3/h
P150	DN150 (6"), P.P. lining, liquid maximum temperature 60 °C measuring range 0...25,6/0...640 m3/h
T150	DN150 (6"), PTFE lining, liquid maximum temperature 110 °C measuring range 0...25,6/0...640 m3/h
HT150	DN150 (6"), PFA lining, liquid maximum temperature 180 °C measuring range 0...25,6/0...640 m3/h
R150	DN150 (6"), RILSAN lining, liquid maximum temperature 70 °C measuring range 0...25,6/0...640 m3/h
E200	DN200 (8"), Ebonite lining, liquid maximum temperature 80 °C measuring range 0...45,2/0...1130 m3/h
T200	DN200 (8"), PTFE lining, liquid maximum temperature 110 °C measuring range 0...45,2/0...1130 m3/h
HT200	DN200 (8"), PFA lining, liquid maximum temperature 180 °C measuring range 0...45,2/0...1130 m3/h
R200	DN200 (8"), RILSAN lining, liquid maximum temperature 70 °C measuring range 0...45,2/0...1130 m3/h
E250	DN250 (10"), Ebonite lining, liquid maximum temperature 80 °C measuring range 0...70,8/0...1770 m3/h
T250	DN250 (10"), PTFE lining, liquid maximum temperature 110 °C measuring range 0...70,8/0...1770 m3/h
HT250	DN250 (10"), PFA lining, liquid maximum temperature 180 °C measuring range 0...70,8/0...1770 m3/h
R250	DN250 (10"), RILSAN lining, liquid maximum temperature 70 °C measuring range 0...70,8/0...1770 m3/h
E300	DN300 (12"), Ebonite lining, liquid maximum temperature 80 °C measuring range 0...100,8/0...2520 m3/h

	T300	DN300 (12"), PTFE lining, liquid maximum temperature 110 °C measuring range 0...100,8/0...2520 m3/h
	HT300	DN300 (12"), PFA lining, liquid maximum temperature 180 °C measuring range 0...100,8/0...2520 m3/h
	R300	DN300 (12"), RILSAN lining, liquid maximum temperature 70 °C measuring range 0...100,8/0...2520 m3/h
	E350	DN350 (14"), Ebonite lining, liquid maximum temperature 80 °C measuring range 0...138/0...3450 m3/h
	T350	DN350 (14"), PTFE lining, liquid maximum temperature 110 °C measuring range 0...138/0...3450 m3/h
	R350	DN350 (14"), RILSAN lining, liquid maximum temperature 70 °C measuring range 0...138/0...3450 m3/h
	E400	DN400 (16"), Ebonite lining, liquid maximum temperature 80 °C measuring range 0...180/0...4500 m3/h
	T400	DN400 (16"), PTFE lining, liquid maximum temperature 110 °C measuring range 0...180/0...4500 m3/h
	R400	DN400 (16"), RILSAN lining, liquid maximum temperature 70 °C measuring range 0...180/0...4500 m3/h
	E450	DN450 (18"), Ebonite lining, liquid maximum temperature 80 °C measuring range 0...228,8/0...5720 m3/h
	T450	DN450 (18"), PTFE lining, liquid maximum temperature 110 °C measuring range 0...228,8/0...5720 m3/h
	E500	DN500 (20"), Ebonite lining, liquid maximum temperature 80 °C measuring range 0...284/0...7100 m3/h
	T500	DN500 (20"), PTFE lining, liquid maximum temperature 110 °C measuring range 0...284/0...7100 m3/h
	E550	(22"), Ebonite lining, liquid maximum temperature 80 °C measuring range 0...348/0...8712m3/h
	E600	DN600 (24"), Ebonite lining, liquid maximum temperature 80 °C measuring range 0...408/0...10200 m3/h
	T600	DN600 (24"), PTFE lining, liquid maximum temperature 110 °C measuring range 0...408/0...10200 m3/h
	E650	(26"), Ebonite lining, liquid maximum temperature 80 °C measuring range 0...480/0...12000 m3/h
	T650	(26"), PTFE lining, liquid maximum temperature 110 °C measuring range 0...480/0...12000 m3/h
	E700	DN700, Ebonite lining, liquid maximum temperature 80 °C measuring range 0...560/0...14000 m3/h
	T700	DN700, PTFE lining, liquid maximum temperature 110 °C measuring range 0...560/0...14000 m3/h
	E750	(30"), rEbonite lining, liquid maximum temperature 80 °C measuring range 0...640/0...16000 m3/h
	T750	(30"), PTFE lining, liquid maximum temperature 110 °C measuring range 0...640/0...16000 m3/h
	E800	DN800, Ebonite lining, liquid maximum temperature 80 °C measuring range 0...720/0...18000 m3/h
	T800	DN800, PTFE lining, liquid maximum temperature 110 °C measuring range 0...720/0...18000 m3/h
	E850	(34"), Ebonite lining, liquid maximum temperature 80 °C measuring range 0...820/0...20500 m3/h
	T850	(34"), PTFE lining, liquid maximum temperature 110 °C measuring range 0...820/0...20500 m3/h
	E900	DN900 (36"), Ebonite lining, liquid maximum temperature 80 °C measuring range 0...920/0...23000 m3/h
	T900	DN900 (36"), PTFE lining, liquid maximum temperature 110 °C measuring range 0...920/0...23000 m3/h
	E1000	DN1000 (40"), Ebonite lining, liquid maximum temperature 80 °C measuring range 0...1140/0...28500 m3/h
	T1000	DN1000 (40"), PTFE lining, liquid maximum temperature 110 °C measuring range 0...1140/0...28500 m3/h
	E1050	DN1050 (42"), Ebonite lining, liquid maximum temperature 80 °C measuring range 0...1270/0...31752 m3/h
	E1200	DN1200 Ebonite lining, liquid maximum temperature 80 °C PN 16 measuring range - 1.600 - 40.000 m3/h
	E1400	DN 1400 Ebonite lining, liquid maximum temperature 80 °C PN 16 measuring range - 2.200 - 55.000 m3/h
	E1600	DN 1600 Ebonite lining, liquid maximum temperature 80 °C PN 16 measuring range - 2.880 - 72.000 m3/h
	E1800	DN1800 Ebonite lining, liquid maximum temperature 80 °C PN 16 measuring range - 3.640 - 91.000 m3/h
Gasket material (internal tightness - only PP lining)		
A	A	No O-Ring (ONLY FOR PTFE/EBANITE LINING)
	B	O-Ring : FKM
	C	O-Ring : Epdm
	Z	O-Ring : da specificare

Flange type		
1	1	Flange EN1092 PN16 (standard with Polypropilene lining)
	2	Flange EN1092 PN10
	3	Flange EN1092 PN25
	4	Flange EN1092 PN40
	5	Flange EN1092 PN64
	6	Flange ANSI 150RF
	7	Flange ANSI 300RF
	8	Flange EN1092 PN6
	9	Flange JIS 10K
	0	Flange: to be specified
Body and Flanges material		
A	A	Body and flange in Carbon Steel painted
	B	Body and flange in Stainless Steel (AISI304) (NOT AVAILABLE FOR LINING IN RILSAN)
	C	Body and flange in Stainless Steel (AISI316) (NOT AVAILABLE FOR LINING IN RILSAN)
	Z	Body and flange material: other
Number and electrodes material		
2	2	n. 3 (2 measure + 1 for ground) electrodes in AISI316
	4	n. 3 (2 measure + 1 for ground) electrodes in Hastelloy C
	5	n. 3 (2 measure + 1 for ground) electrodes in Titanium
	6	n. 3 (2 measure + 1 for ground) electrodes in Tantalum; not available with Polypropilene/Rilsan
	7	n. 3 (2 measure + 1 for ground) electrodes in Platinum; not available with Polypropilene/Rilsan
	0	Electrode material: to be specified
Version / Sensor protection class		
A	A	Compact version , IP67 protection rate
	B	Separate version, Painted Aluminum JB, protection rate IP68, standing immersion with 1,5 m of head water - (DEFINE THE CABLE LENGHT - ADD THE COST)
	G	Separate version, Painted Aluminum JB, N° 1 connectors IP 68 suitable for fast cable connections - (DEFINE THE CABLE LENGHT - ADD THE COST)
	F	Separate version, Painted Aluminum JB, N° 2 connectors IP 68 suitable for fast cable connections - (DEFINE THE CABLE LENGHT - ADD THE COST)
	N	Separate version, Painted Aluminum JB , PREAMPLIFIRE*, protection rate IP67 - (DEFINE THE CABLE LENGHT MAX 500 m-ADD THE COST)
	Q	Separate version, Painted Aluminum JB, PREAMPLIFIRE*, N° 1 connectors IP 68 suitable for fast cable connection - (DEFINE THE CABLE LENGHT MAX 500 m-ADD THE COST)
	U	Separate version, AISI 304 JB RAW, protection rate IP68, standing immersion with 1,5 m of head water - (DEFINE THE CABLE LENGHT - ADD THE COST)
	S	Separate version, AISI 304 JB RAW, with N° 1 connectors IP 68 suitable for fast cable connections - (DEFINE THE CABLE LENGHT - ADD THE COST)
	T	Separate version, AISI 304 JB RAW, N° 2 connectors IP 68 suitable for fast cable connections - (DEFINE THE CABLE LENGHT - ADD THE COST)
	P	Separate version, AISI 304 JB RAW, PREAMPLIFIRE*, protection rate IP67 - (DEFINE THE CABLE LENGHT MAX 500 m-ADD THE COST)
	R	Separate version, AISI 304 JB RAW, PREAMPLIFIRE* N° 1 connectors IP 68 suitable for fast cable connections to - (DEFINE THE CABLE LENGHT MAX 500 m-ADD THE COST)
K	Separate version, AISI 304 JB POLISCHED, protection rate IP68, standing immersion with 1,5 m of head water - (DEFINE THE CABLE LENGHT - ADD THE COST)	

Y	Separate version, AISI 304 JB POLISCHED, with N° 1 connectors IP 68 suitable for fast cable connections - (DEFINE THE CABLE LENGHT - ADD THE COST)
W	Separate version, AISI 304 JB POLISCHED, N° 2 connectors IP 68 suitable for fast cable connections - (DEFINE THE CABLE LENGHT - ADD THE COST)
V	Separate version, AISI 304 JB POLISCHED, PREAMPLIFIRE*, protection rate IP67 - (DEFINE THE CABLE LENGHT MAX 500 m-ADD THE COST)
J	Separate version, AISI 304 JB POLISCHED, PREAMPLIFIRE* N° 1 connectors IP 68 suitable for fast cable connections to - (DEFINE THE CABLE LENGHT MAX 500 m-ADD THE COST)

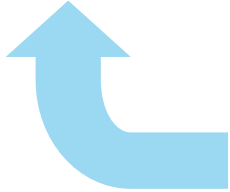

MS2500-T100-A1A2A (Example of Complete code for order)

ISOIL INDUSTRIA S.p.A.

HEAD OFFICE	SERVICE
Via Fratelli Gracchi, 27 20092 Cinisello Balsamo (MI) Tel +39 02 66027.1 Fax +39 02 6123202 vendite@isoil.it	isomagservice@isoil.it

If you want to find the complete list of our distributors access at the following link:
http://www.isoil.com/u_vendita.asp



Due to the constant technical development and improvement of its products, the manufacturer reserves the right to make changes and/or modify the information contained in this document without notice.