

**Non Contact  
Open Channel  
Flow Measurement System**

**Q-Eye RADAR MT**

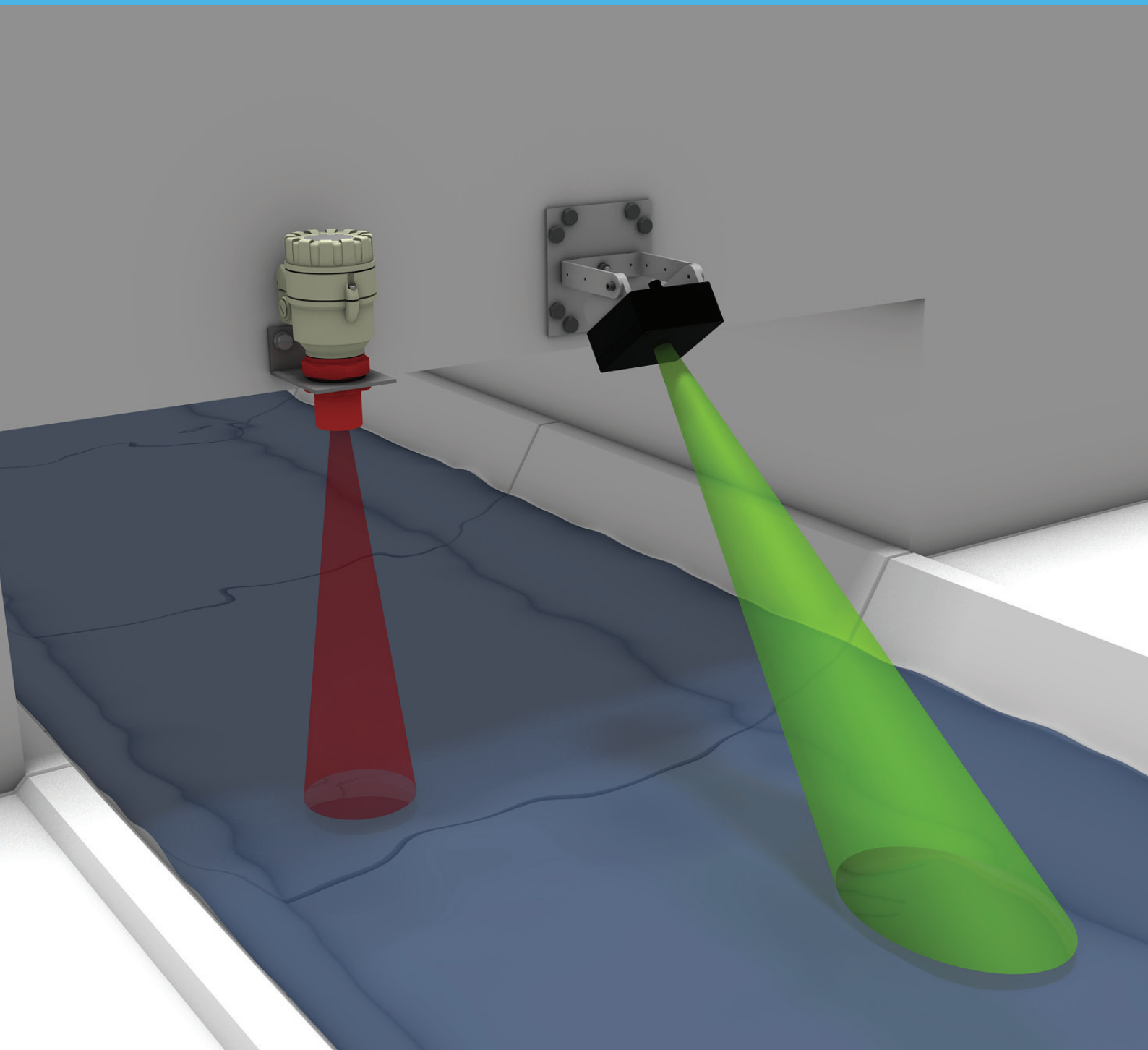



# Q-Eye Radar MT

## Application

The **Q-Eye Radar MT** is a non-contact open channel flow meter. It consists of a radar-based velocity sensor and an ultrasonic or radar based water level sensor.

The system is designed for continuous operation and suitable for measurements of flows not only in rivers and open channels, but also in municipal waste water and storm water sewers. Compact construction combined with the contact-free measurement principle enables an easy installation and use.

In some applications it is an advantage to have a non-contact measurement. When combining both **Radar** and **Water level** transmitter, they provide a revolutionary approach to open channel and sewer flow monitoring. Combined are pulse wave radar velocity sensing technology with ultrasonic or radar pulse echo level sensing to remotely measure open channel flows.

The velocities present on the surface are typically within 10% of the average velocity.

HydroVision has developed a **Finite-Difference-Algorithm** that yields to an accurate determination of the average velocity from the measurement of the surface velocity at a know point of the flow surface.

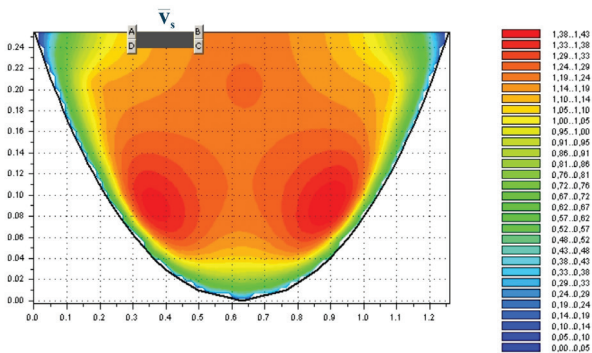

## Advantages

- » Accurate flow measurements
- » Easy installation
- » No need to stop flow
- » Bi-directional velocity measurements
- » No need of periodical cleaning as required by submerged type sensors (e.g. caused by fouling)
- » Integrated inclination sensor (RV30)
- » Optional surcharge water level sensor
- » No contact of personnel with fluid during installation

## Inclination Sensor

The radar sensor type RV30 comes with an integrated **inclination** sensor which after each measurement automatically checks its own position. It measures the inclination so that installation errors or any unwanted repositioning of the sensor are detected and can be corrected. This eliminates measurement errors.

## Surcharge Conditions

Thanks to the optional surcharge depth and velocity sensor, the system can also be used in situations where flow changes from open channel flow to surcharged conditions (e.g. in sewers).

## Installation

The **maximum** permissible installation height above the surface of the water is 30 m (98 ft.) for rivers and open channels and RV30. For waste water applications we suggest 10 m (32 ft.) and sensor type RV11.

The **minimum** distance to the surface of the water in direction of transmission is 0,5 m (19.2 in) for type RV30 and 0,2 m (7.87 in) for sensor type RV11.

# Technical Information

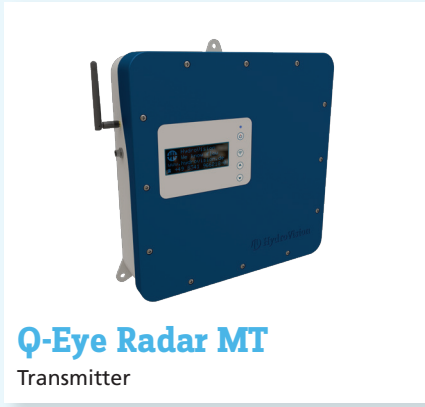

Q-Eye Radar MT is a major improvement in open channel flow measurement. This flow computer incorporates all of the required algorithms and software to ensure accuracy and repeatability. The IP65 (NEMA 4X) compact flow display computer has a 4x20 alphanumeric LCD display and a 4 button keypad. All configuration data and measured and calculated data are stored inside an 16GB Micro-SD card. It controls the measurements, calculates the flow rate and provides freely programmable current outputs, status alarm, frequency outputs and totalizer readings.

The unit can be mounted up to 100 m (330 feet) far away from the velocity and water level sensor. The unit is available with AC and DC power supply options.



Parameterization of the measurement site and data visualization is easily possible using the standard web-browser of your already existing smartphone, tablet PC or notebook – there is no need for any additional software or App. The interface is graphical and menu-driven for rapid commissioning.

This allows for your flow meter to be accessed from anywhere - anytime 24/7.

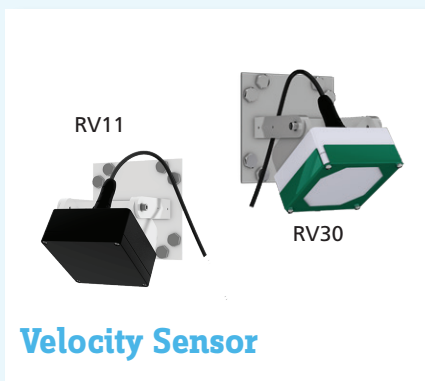

The **velocity sensor** is operating at the free 24 GHz band frequencies and makes use of the Doppler effect to produce velocity data about the speed of the moving surface. It does this by beaming a microwave signal to the flow surface at a defined angle and listening for its reflection at particles and disturbances on the surface moving with the flow. The frequency of these returning signals have been shifted by an amount directly proportional to the speed of the moving surface. This frequency shift is measured by means of a Fast-Fourier-Transformation (FFT). The velocity is calculated based on knowledge of the radar frequency, speed of light and average frequency shift.



The **ultrasonic level sensor** operates by energizing a piezoelectric transducer with an electronic pulse. This pulse creates a pressure wave that travels to the flow surface where a portion returns to the transducer. The transit-time to the flow surface and back is recorded and the distance calculated by knowing the speed of sound at the site which has been corrected by an embedded temperature sensor. Alternatively, the system can be equipped with an additional radar water level sensor.

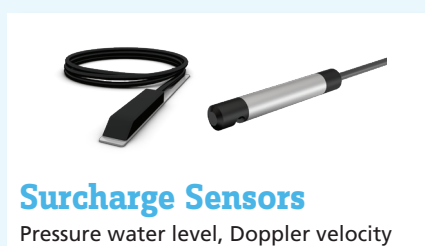

For some applications, flow conditions change from open channel flow to **surcharged** conditions (e.g. in sewers). Since neither the radar velocity sensor nor the ultrasonic depth sensor provide any useful information when submerged, Q-Eye Radar MT can be equipped with an optional depth sensor (**pressure transducer**) and velocity (**Doppler**) sensor which provide continuous measurement of flow data when the sewer is flowing full and gravity-flow no longer prevails.

# Technical Data

## Transmitter

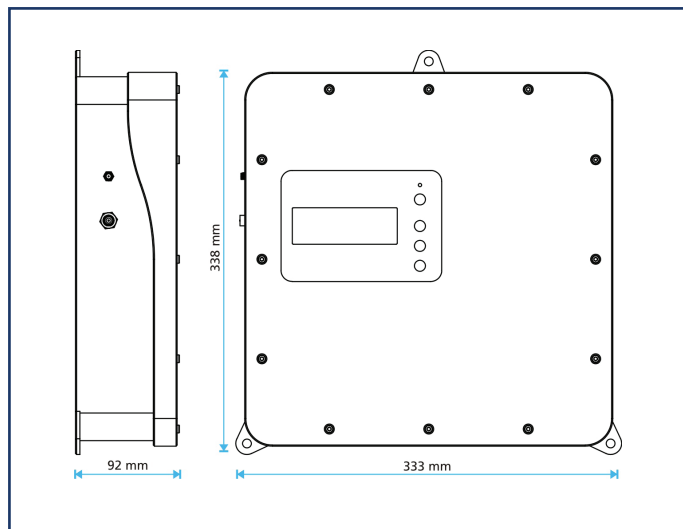

## Sensors & Mounting

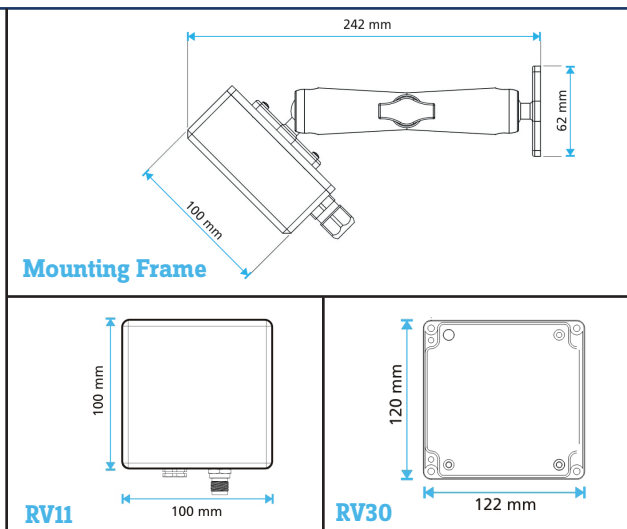

## Q-Eye Radar MT

### Specifications Sensor

	RV30	RV11
Frequency:	24 GHz	24 GHz
Beamwidth:	10° at -3dB	11° at -3dB
Range:	± 0,3 to ± 15 m/s	± 0,05 m/s to ± 15 m/s
Resolution:	1 mm/s; min. wave height 3mm	
Accuracy Q:	< 2,5% of reading under normal flow conditions	
V-Sensor:	bi-directional	
Min. Distance to surface	0,5 m	0,2 m
Max. Distance to surface	30 m	10 m
Inclination Sensor:	yes	no
Protection Class:	IP68	IP68

### Specifications Transmitter

Display:	4 lines, 20 characters
Keyboard:	4 keys
Datalogger:	16GB MicroSD Card
Communication:	RS485, Modbus (RS232 or RS485), WLAN, GPRS, Ethernet 10/100 Mbps
Inputs:	max. 4 x 4-20 mA, 2x digital
Outputs:	max. 4 x 4-20 mA, 2x digital, 4x Relay
Power Supply:	85-260 V <sub>AC</sub> (48-60 Hz) or 9-36 V <sub>DC</sub>
Protection Class:	IP 65
Enclosure:	ABS, wall mounted

## Ultrasonic Level

### Specifications

	WLU3902	WLU3802	WLU3702
Frequency:	80 kHz	80 kHz	60 kHz
Range:	0,2 - 4 m (0.65 - 13 ft.)	0,25 - 6 m (0.82 - 19.68 ft.)	0,35 - 8 m (1.2 - 26 ft.)
Accuracy *):	± (0,2% of measured distance + 0,05% of range)		
Beam Angle:	6°	5°	7°
Sensor Material:	PP, PVDF or PTFE		
Housing Material:	Plastic / Aluminum		
Operating Temperature:	-30°C ... +90°C (-22 to + 194 °F)		
Power Supply:	24 V <sub>DC</sub>		
Mounting:	1 1/2" BSP/NPT	2" BSP/NPT	2" BSP/NPT
Protection Class:	Sensor: IP 68 Housing: IP 67		
Approval:	ATEX (Option, II G/Ex ia IIB T6)		
Electrical Connection:	Standard version: 2x M20x1.5 plastic cable gland; Cable: Ø 6...12 mm Ex version: 2x M20x1.5 metal cable gland; Cable: Ø 7...13 mm Wire cross section: 0.5...1.5 mm²		

Further details and drawings of Ultrasonic Level please refer to separate brochure.  
\*) under optimum conditions and stabilized transducer temperature

## HydroVision GmbH

Gewerbestraße 46f  
87600 Kaufbeuren  
Germany

tel. +49 - 8341 - 9662180  
fax +49 - 8341 - 9666030

info@hydrovision.de  
www.hydrovision.de

## HydroVision Americas

110 Cavalier Dr.  
Pensacola, FL 32507  
USA

tel. +1 - (850) - 857 9855

americas@hydrovision.de  
www.hydrovision.de

represented by:

