

MAGNETIC SWITCHES

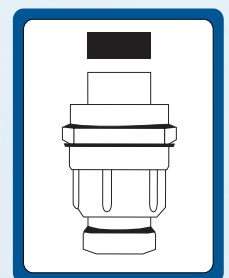
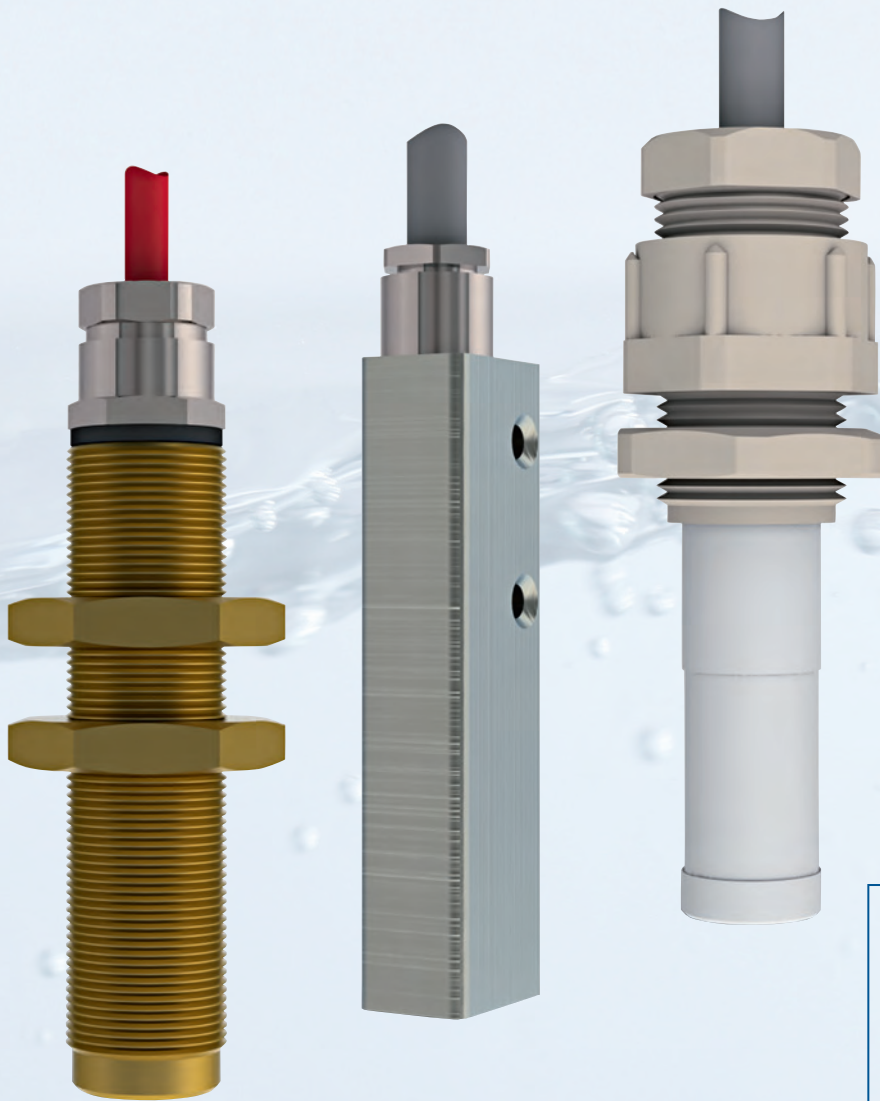

Table of content

Magnetic Switches / Content.....	184
Magnetic Switches / Function description.....	185
Magnetic Switches / Type key.....	186
Magnetic Switches / Type key.....	187
Magnetic Switches / Stainless steel.....	188
Magnetic Switches / Stainless steel.....	189
Magnetic Switches / Brass.....	190
Magnetic Switches / Brass.....	191
Magnetic Switches / Polyamide.....	192
Magnetic Switches / Polyamide.....	193
Magnetic Switches / Polyamide.....	194
Magnetic Switches / Polyamide.....	195
Magnetic Switches / Polyamide.....	196
Magnetic Switches / Polyamide.....	197
Magnetic Switches / Polyamide.....	198
Magnetic Switches / Polyamide.....	199
Magnetic Switches / Polyethylene.....	200
Magnetic Switches / Polyethylene.....	201
Magnetic Switches / Aluminium.....	202
Magnetic Switches / Magnets / Actuation distances.....	203

KÜBLER
SWISS

Magnetic Switches / Type key

Code 1

Key 1 ... / ... - Electrical connection		Key 2 ... / ... - Installation connection	
K	Connection cable	E	Thread upwards, G/BSP
K68	Connection cable IP 68 (only for G 3/8")	LM	Thread longitudinal, metric
		PG	PG cable entry
		OP	Without mounting connection

Code 2

Key 1 ... - Threaded connection	
...	Thread size

Code 3

Key 1 ... / ... / ... / ... - Housing material quality		Key 2 ... / ... / ... / ... - Switch function		Key 3 ... / ... / ... / ... - Switch option	
V	Stainless steel	U	Change over	R22	Switch protective circuit with 22 ohm / 0.21 W resistor
ME	Brass	S	Normally open	N	Switch protective circuit according to NAMUR EN 60947
AL	Aluminium	O	Normally closed		
PA	Polyamide				
PE	Polyethylene				

Code 3

Key 4 ... / ... / ... / ... - Contact material / Switch behaviour		Key 5 ... / ... / ... / ... - Actuation	
RMO	Rhodium Monostable	STB	Front activated
RBI	Rhodium Bistable	SEB	Side activated
WMO	Wolfram Monostable		

Code 4

Key 1 ... - Housing length	
L...	Housing length in mm

Code 5

Key 1 ... - Form of housing	
RU	Round contact profile
RE	Angular contact profile

Example

Code	1	2	3	4	5	6	7
Key	1 / 2 - 1 - 1 / 2 / 3 / 4 / 5 - 1 - 1 - 1 / 2 / 3 - 1 / 2						
Example	K / E - 3/8 - V / S / R22 / RMO / STB - L70 - RU - 1 / PVCB / KA - EXIAG /						

Black = not possible according to Atex / Blue = possible according to Atex Exia / Blue¹ = possible according to Atex Exia and Exd / Black¹ = possible according to Atex Exd

Code 6

Key 1 ... / ... / ... - Length of cable	Key 2 ... / ... / ... - Connection cable	Key 3 ... / ... / ... - Connection cable option
... Length of cable in meter	PVC ¹ PVC connection cable PVCB ¹ PVC connection cable with blue coating SIL ¹ Silicone connection cable PUR ¹ PUR connection cable RAD ¹ Radox connection cable	KA ¹ Shielded KB ¹ Shielded / oil-resistant KC ¹ Shielded / oil-resistant / halogen-free KD ¹ Oil-resistant KE ¹ Oil-resistant / halogen-free KF ¹ Halogen-free

Code 7

Key 1 ... / ... - Approvals / 1	Key 2 ... / ... - Approvals / 2
EXIAG Acc. to Exia, atmosphere gas EXIAGD Acc. to Exia, atmosphere gas and dust EXMG Acc. to Exm, atmosphere gas EXMGD Acc. to Exm, atmosphere gas and dust	GL Approval Germanischer Lloyd BV Approval Bureau Veritas ABS Approval American Bureau of Shipping



Example

Code	1	2	3	4	5	6	7
Key	1 / 2 - 1 - 1 / 2 / 3 / 4 / 5 - 1 - 1 - 1 / 2 / 3 - 1 / 2						
Example	K / E - 3/8 - V / S / R22 / RMO / STB - L70 - RU - 1 / PVCB / KA - EXIAG /						

Black = not possible according to Atex / Blue = possible according to Atex Exia / Blue¹ = possible according to Atex Exia and Exd / Black¹ = possible according to Atex Exd

Magnetic Switches / Stainless steel

Type

K/E-3/8-V/S/RMO/STB-L70-RU-../PVC

Material quality:	Stainless steel
Electrical connection:	Connection cable
Ambient temperature	
- with PVC connection cable:	-20°C ... +80°C
- with Silicone connection cable:	-60°C ... +180°C
- with PUR connection cable:	-40°C ... +80°C
Installation connection:	G 3/8"

Switch function:	Normally open
Contact material:	Rhodium
Switch behaviour:	Monostable
Switching capacity:	230 V / 1.0 A / 100 VA
Switching capacity ATEX Exia / Exm:	100 mA / NAMUR 60 mA
Switching frequency:	300 / sec.
Switching hysteresis:	ca. 5 mm

Actuation distances / Magnets page 203	
Actuation:	Front activated

Design pressure:	0 bar ... 0.5 bar
Design temperature:	-60°C ... +180°C
Ingress protection class:	IP 55

Approvals / Certificates:	ATEX / GL / BV / ABS / SIL1
---------------------------	-----------------------------

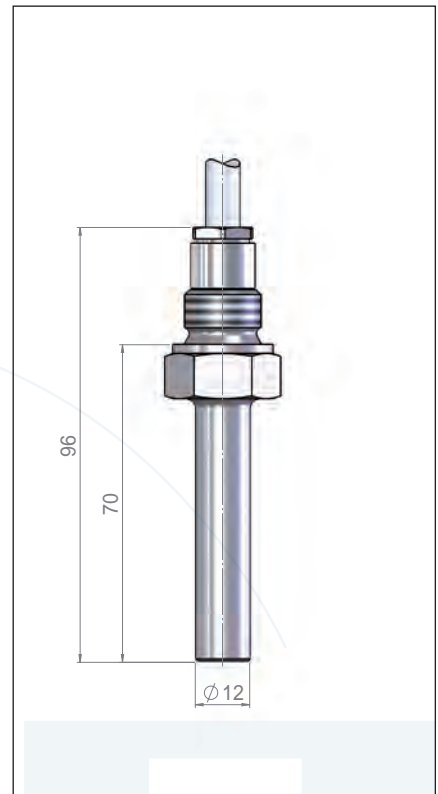

Type

K/E-3/8-V/U/RMO/STB-L70-RU-../PVC

Material quality:	Stainless steel
Electrical connection:	Connection cable
Ambient temperature	
- with PVC connection cable:	-20°C ... +80°C
- with Silicone connection cable:	-60°C ... +180°C
- with PUR connection cable:	-40°C ... +80°C
Installation connection:	G 3/8"

Switch function:	Change over
Contact material:	Rhodium
Switch behaviour:	Monostable
Switching capacity:	230 V / 0.5 A / 30 VA
Switching capacity ATEX Exia / Exm:	100 mA / NAMUR 60 mA
Switching frequency:	300 / sec.
Switching hysteresis:	ca. 5 mm

Actuation distances / Magnets page 203	
Actuation:	Front activated

Design pressure:	0 bar ... 0.5 bar
Design temperature:	-60°C ... +180°C
Ingress protection class:	IP 55

Approvals / Certificates:	ATEX / GL / BV / ABS / SIL1
---------------------------	-----------------------------

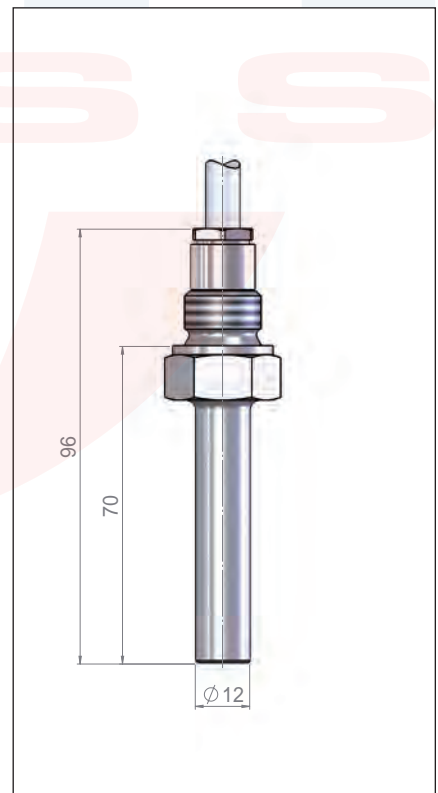

The magnetic switches are based on a modular design and can be conditionally arranged individually.

Type key page 186 - 187

Type

K/E-3/8-V/S/RMO/STB-L100-RU-.../PVC

Material quality:	Stainless steel
Electrical connection:	Connection cable
Ambient temperature	
- with PVC connection cable:	-20°C ... +80°C
- with Silicone connection cable:	-60°C ... +180°C
- with PUR connection cable:	-40°C ... +80°C
Installation connection:	G 3/8"
Switch function:	Normally open
Contact material:	Rhodium
Switch behaviour:	Monostable
Switching capacity:	230 V / 1.0 A / 100 VA
Switching capacity ATEX Exia / Exm:	100 mA / NAMUR 60 mA
Switching frequency:	300 / sec.
Switching hysteresis:	ca. 5 mm
Actuation distances / Magnets page 203	
Actuation:	Front activated
Design pressure:	0 bar ... 0.5 bar
Design temperature:	-60°C ... +180°C
Ingress protection class:	IP 55
Approvals / Certificates:	ATEX / GL / BV / ABS / SIL1

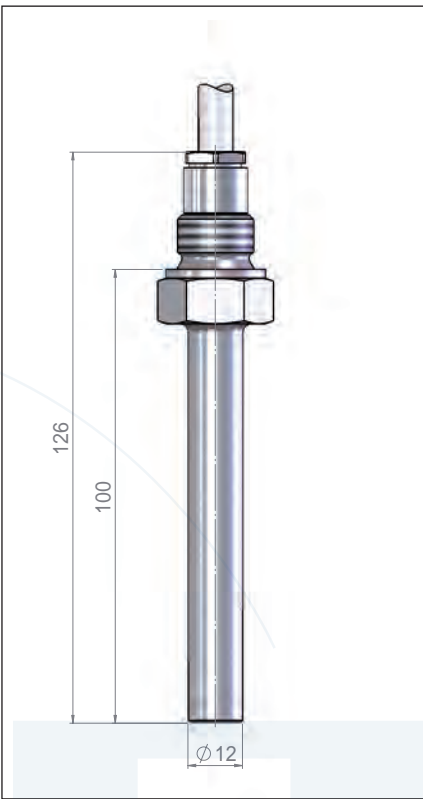

Type

K/E-3/8-V/U/RMO/STB-L100-RU-.../PVC

Material quality:	Stainless steel
Electrical connection:	Connection cable
Ambient temperature	
- with PVC connection cable:	-20°C ... +80°C
- with Silicone connection cable:	-60°C ... +180°C
- with PUR connection cable:	-40°C ... +80°C
Installation connection:	G 3/8"
Switch function:	Change over
Contact material:	Rhodium
Switch behaviour:	Monostable
Switching capacity:	230 V / 0.5 A / 30 VA
Switching capacity ATEX Exia / Exm:	100 mA / NAMUR 60 mA
Switching frequency:	300 / sec.
Switching hysteresis:	ca. 5 mm
Actuation distances / Magnets page 203	
Actuation:	Front activated
Design pressure:	0 bar ... 0.5 bar
Design temperature:	-60°C ... +180°C
Ingress protection class:	IP 55
Approvals / Certificates:	ATEX / GL / BV / ABS / SIL1

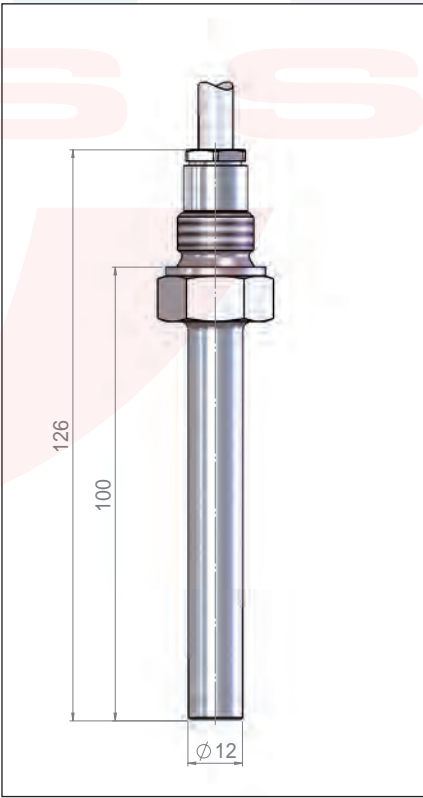

The magnetic switches are based on a modular design and can be conditionally arranged individually.

Type key page 186 - 187

Magnetic Switches / Brass

Type **K/LM-10x1-ME/S/RMO/STB-L40-RU-../PVC**

Material quality:	Brass
Electrical connection:	Connection cable
Ambient temperature	
- with PVC connection cable:	-10°C ... +80°C
- with Silicone connection cable:	-10°C ... +180°C
- with PUR connection cable:	-10°C ... +80°C
Installation connection:	Thread longitudinal, metric M10 x 1 mm
Switch function:	Normally open
Contact material:	Rhodium
Switch behaviour:	Monostable
Switching capacity:	230 V / 1.0 A / 100 VA
Switching capacity ATEX Exia / Exm:	-
Switching frequency:	1000 / sec.
Switching hysteresis:	ca. 5 mm
Actuation distances / Magnets page 203	
Actuation:	Front activated
Design pressure:	0 bar ... 0.5 bar
Design temperature:	-10°C ... +180°C
Ingress protection class:	IP 55
Approvals / Certificates:	GL / BV / ABS / SIL1

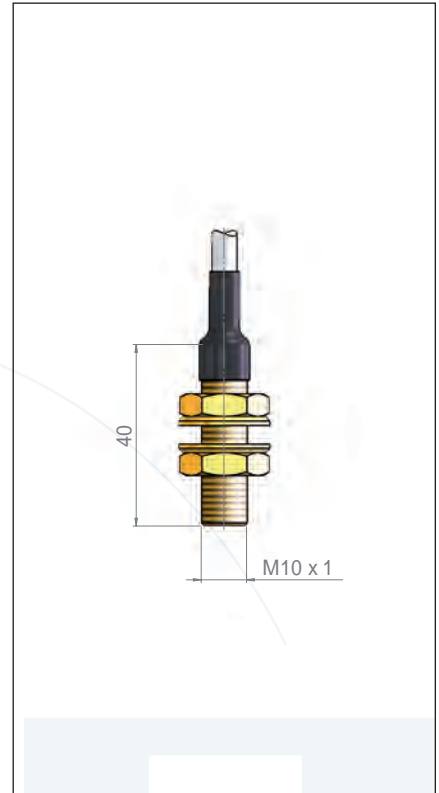

Type **K/LM-10x1-ME/U/RMO/STB-L40-RU-../PVC**

Material quality:	Brass
Electrical connection:	Connection cable
Ambient temperature	
- with PVC connection cable:	-10°C ... +80°C
- with Silicone connection cable:	-10°C ... +180°C
- with PUR connection cable:	-10°C ... +80°C
Installation connection:	Thread longitudinal, metric M10 x 1 mm
Switch function:	Change over
Contact material:	Rhodium
Switch behaviour:	Monostable
Switching capacity:	230 V / 0.5 A / 20 VA
Switching capacity ATEX Exia / Exm:	-
Switching frequency:	1000 / sec.
Switching hysteresis:	ca. 5 mm
Actuation distances / Magnets page 203	
Actuation:	Front activated
Design pressure:	0 bar ... 0.5 bar
Design temperature:	-10°C ... +180°C
Ingress protection class:	IP 55
Approvals / Certificates:	GL / BV / ABS / SIL1

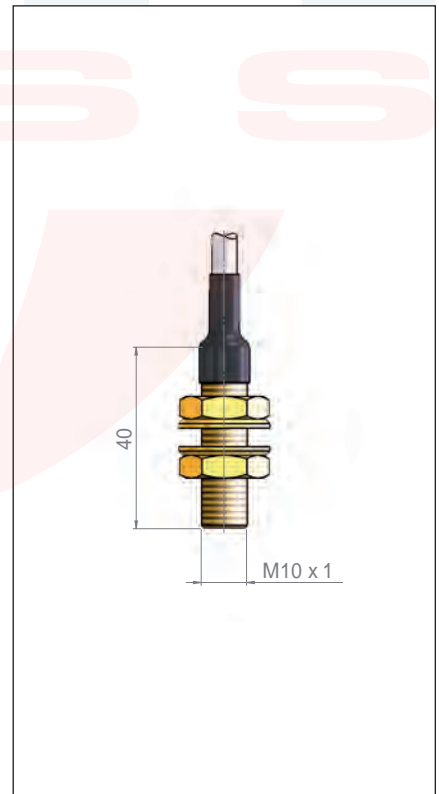

The magnetic switches are based on a modular design and can be conditionally arranged individually.

Type key page 186 - 187

Type **K/LM-12x1-ME/S/RMO/STB-L70-RU-../PVC**

Material quality:	Brass
Electrical connection:	Connection cable
Ambient temperature	
- with PVC connection cable:	-10°C ... +80°C
- with Silicone connection cable:	-10°C ... +180°C
- with PUR connection cable:	-10°C ... +80°C
Installation connection:	Thread longitudinal, metric M12 x 1 mm
Switch function:	Normally open
Contact material:	Rhodium
Switch behaviour:	Monostable
Switching capacity:	230 V / 1.0 A / 100 VA
Switching capacity ATEX Exia / Exm:	-
Switching frequency:	300 / sec.
Switching hysteresis:	ca. 5 mm
Actuation distances / Magnets page 203	
Actuation:	Front activated
Design pressure:	0 bar ... 0.5 bar
Design temperature:	-10°C ... +180°C
Ingress protection class:	IP 55
Approvals / Certificates:	GL / BV / ABS / SIL1

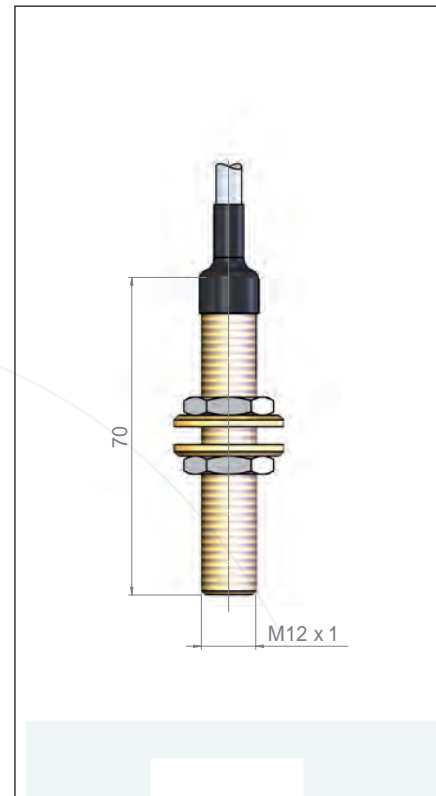

Type **K/LM-12x1-ME/U/RMO/STB-L70-RU-../PVC**

Material quality:	Brass
Electrical connection:	Connection cable
Ambient temperature	
- with PVC connection cable:	-10°C ... +80°C
- with Silicone connection cable:	-10°C ... +180°C
- with PUR connection cable:	-10°C ... +80°C
Installation connection:	Thread longitudinal, metric M12 x 1 mm
Switch function:	Change over
Contact material:	Rhodium
Switch behaviour:	Monostable
Switching capacity:	230 V / 0.5 A / 30 VA
Switching capacity ATEX Exia / Exm:	-
Switching frequency:	300 / sec.
Switching hysteresis:	ca. 5 mm
Actuation distances / Magnets page 203	
Actuation:	Front activated
Design pressure:	0 bar ... 0.5 bar
Design temperature:	-10°C ... +180°C
Ingress protection class:	IP 55
Approvals / Certificates:	GL / BV / ABS / SIL1

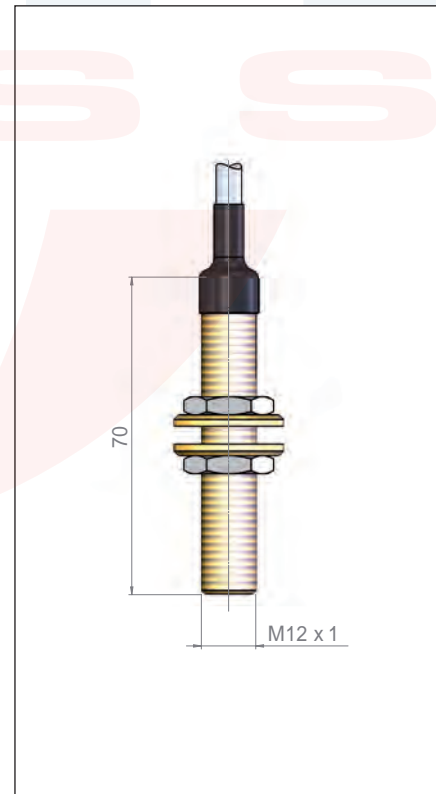

The magnetic switches are based on a modular design and can be conditionally arranged individually.

Type key page 186 - 187

Type **K/PG-9-PA/S/RMO/STB-L50-RU-../PVC**

Material quality:	Polyamide
Electrical connection:	Connection cable
Ambient temperature	
- with PVC connection cable:	-15°C ... +80°C
- with Silicone connection cable:	-15°C ... +80°C
- with PUR connection cable:	-15°C ... +80°C
Installation connection:	PG 9
Switch function:	Normally open
Contact material:	Rhodium
Switch behaviour:	Monostable
Switching capacity:	230 V / 1.0 A / 100 VA
Switching capacity ATEX Exia / Exm:	-
Switching frequency:	1000 / sec.
Switching hysteresis:	ca. 5 mm
Actuation distances / Magnets page 203	
Actuation:	Front activated
Design pressure:	0 bar ... 0.5 bar
Design temperature:	-15°C ... +80°C
Ingress protection class:	IP 65
Approvals / Certificates:	GL / BV / ABS / SIL1

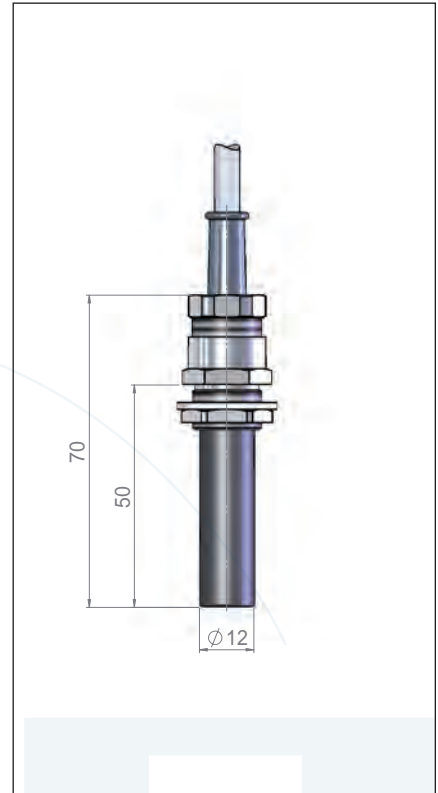

Type **K/PG-9-PA/S/RMO/STB-L60-RU-../PVC**

Material quality:	Polyamide
Electrical connection:	Connection cable
Ambient temperature	
- with PVC connection cable:	-15°C ... +80°C
- with Silicone connection cable:	-15°C ... +80°C
- with PUR connection cable:	-15°C ... +80°C
Installation connection:	PG 9
Switch function:	Normally open
Contact material:	Rhodium
Switch behaviour:	Monostable
Switching capacity:	230 V / 1.0 A / 100 VA
Switching capacity ATEX Exia / Exm:	-
Switching frequency:	300 / sec.
Switching hysteresis:	ca. 5 mm
Actuation distances / Magnets page 203	
Actuation:	Front activated
Design pressure:	0 bar ... 0.5 bar
Design temperature:	-15°C ... +80°C
Ingress protection class:	IP 65
Approvals / Certificates:	GL / BV / ABS / SIL1

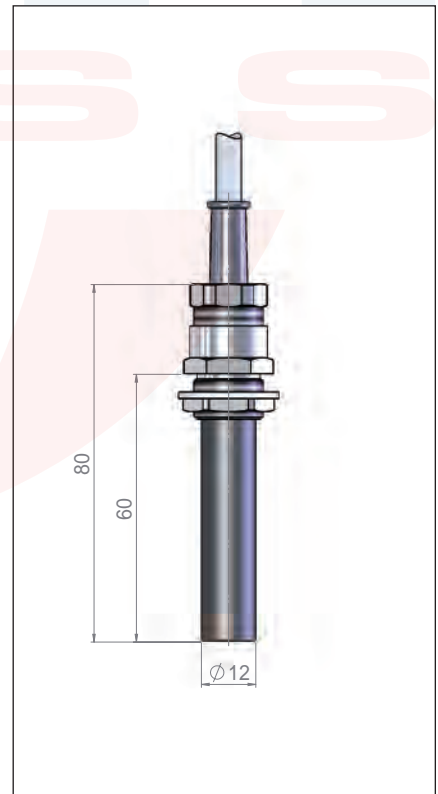

The magnetic switches are based on a modular design and can be conditionally arranged individually.

Type key page 186 - 187

Type **K/PG-9-PA/U/RMO/STB-L60-RU-../PVC**

Material quality:	Polyamide
Electrical connection:	Connection cable
Ambient temperature	
- with PVC connection cable:	-15°C ... +80°C
- with Silicone connection cable:	-15°C ... +80°C
- with PUR connection cable:	-15°C ... +80°C
Installation connection:	PG 9

Switch function:	Change over
Contact material:	Rhodium
Switch behaviour:	Monostable
Switching capacity:	230 V / 0.5 A / 30 VA
Switching capacity ATEX Exia / Exm:	-
Switching frequency:	300 / sec.
Switching hysteresis:	ca. 5 mm

Actuation distances / Magnets page 203	
Actuation:	Front activated

Design pressure:	0 bar ... 0.5 bar
Design temperature:	-15°C ... +80°C
Ingress protection class:	IP 65

Approvals / Certificates:	GL / BV / ABS / SIL1
---------------------------	----------------------

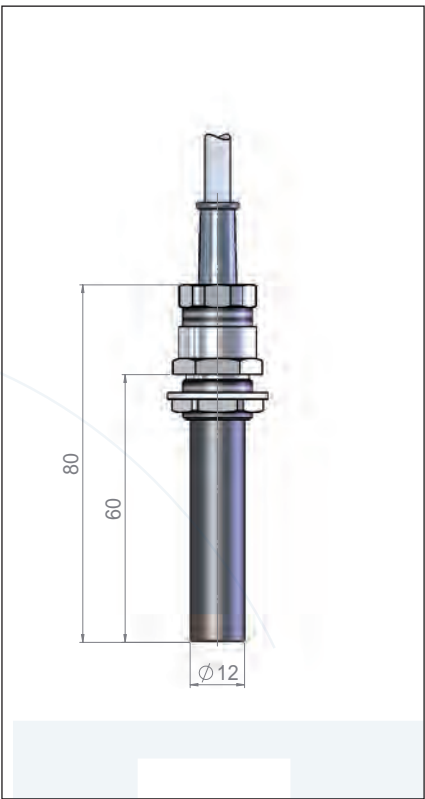

Type **K/PG-9-PA/U/WMO/STB-L60-RU-../PVC**

Material quality:	Polyamide
Electrical connection:	Connection cable
Ambient temperature	
- with PVC connection cable:	-15°C ... +80°C
- with Silicone connection cable:	-15°C ... +80°C
- with PUR connection cable:	-15°C ... +80°C
Installation connection:	PG 9

Switch function:	Change over
Contact material:	Wolfram
Switch behaviour:	Monostable
Switching capacity:	230 V / 0.5 A / 30 VA
Switching capacity ATEX Exia / Exm:	-
Switching frequency:	100 / sec.
Switching hysteresis:	ca. 2 - 3 mm

Actuation distances / Magnets page 203	
Actuation:	Front activated

Design pressure:	0 bar ... 0.5 bar
Design temperature:	-10°C ... +80°C
Ingress protection class:	IP 65

Approvals / Certificates:	GL / BV / ABS / SIL1
---------------------------	----------------------

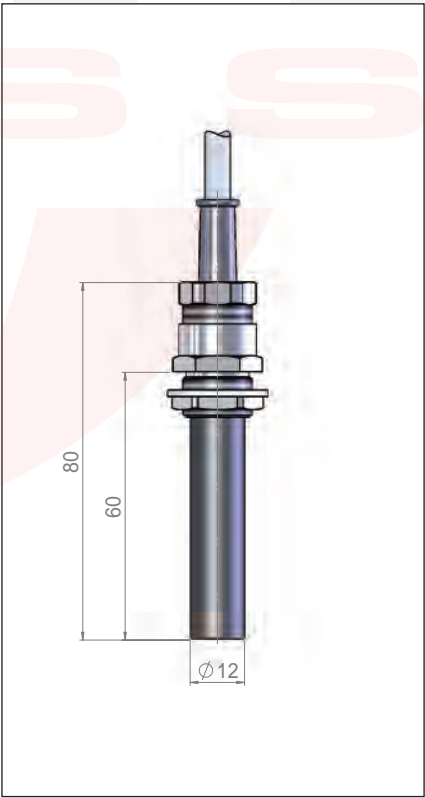

The magnetic switches are based on a modular design and can be conditionally arranged individually.
Type key page 186 - 187

Type **K/PG-9-PA/S/RMO/SEB-L80-RU-../PVC**

Material quality:	Polyamide
Electrical connection:	Connection cable
Ambient temperature	
- with PVC connection cable:	-15°C ... +80°C
- with Silicone connection cable:	-15°C ... +80°C
- with PUR connection cable:	-15°C ... +80°C
Installation connection:	PG 9
Switch function:	Normally open
Contact material:	Rhodium
Switch behaviour:	Monostable
Switching capacity:	230 V / 1.0 A / 100 VA
Switching capacity ATEX Exia / Exm:	-
Switching frequency:	300 / sec.
Switching hysteresis:	ca. 3 - 5 mm
Actuation distances / Magnets page 203	
Actuation:	Side activated
Design pressure:	0 bar ... 0.5 bar
Design temperature:	-15°C ... +80°C
Ingress protection class:	IP 65
Approvals / Certificates:	GL / BV / ABS / SIL1

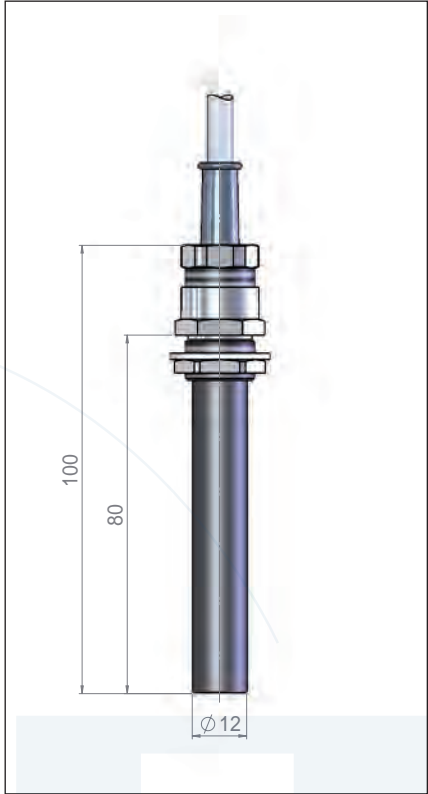

Type **K/PG-9-PA/U/RMO/SEB-L80-RU-../PVC**

Material quality:	Polyamide
Electrical connection:	Connection cable
Ambient temperature	
- with PVC connection cable:	-15°C ... +80°C
- with Silicone connection cable:	-15°C ... +80°C
- with PUR connection cable:	-15°C ... +80°C
Installation connection:	PG 9
Switch function:	Change over
Contact material:	Rhodium
Switch behaviour:	Monostable
Switching capacity:	230 V / 0.5 A / 30 VA
Switching capacity ATEX Exia / Exm:	-
Switching frequency:	300 / sec.
Switching hysteresis:	ca. 3 - 5 mm
Actuation distances / Magnets page 203	
Actuation:	Side activated
Design pressure:	0 bar ... 0.5 bar
Design temperature:	-15°C ... +80°C
Ingress protection class:	IP 65
Approvals / Certificates:	GL / BV / ABS / SIL1

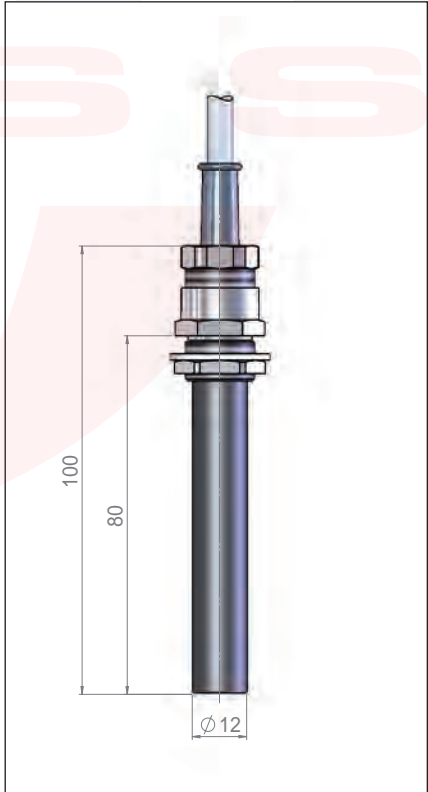

The magnetic switches are based on a modular design and can be conditionally arranged individually.

Type key page 186 - 187

Type **K/PG-16-PA/S/RBI/STB-L75-RU-../PVC**

Material quality:	Polyamide
Electrical connection:	Connection cable
Ambient temperature	
- with PVC connection cable:	-15°C ... +80°C
- with Silicone connection cable:	-15°C ... +80°C
- with PUR connection cable:	-15°C ... +80°C
Installation connection:	PG 16

Switch function:	Normally open
Contact material:	Rhodium
Switch behaviour:	Bistable
Switching capacity:	230 V / 1.0 A / 100 VA
Switching capacity ATEX Exia / Exm:	-
Switching frequency:	1000 / sec.
Switching hysteresis:	-

Actuation distances / Magnets page 203	
Actuation:	Front activated

Design pressure:	0 bar ... 0.5 bar
Design temperature:	-15°C ... +80°C
Ingress protection class:	IP 65

Approvals / Certificates:	GL / BV / ABS / SIL1
---------------------------	----------------------

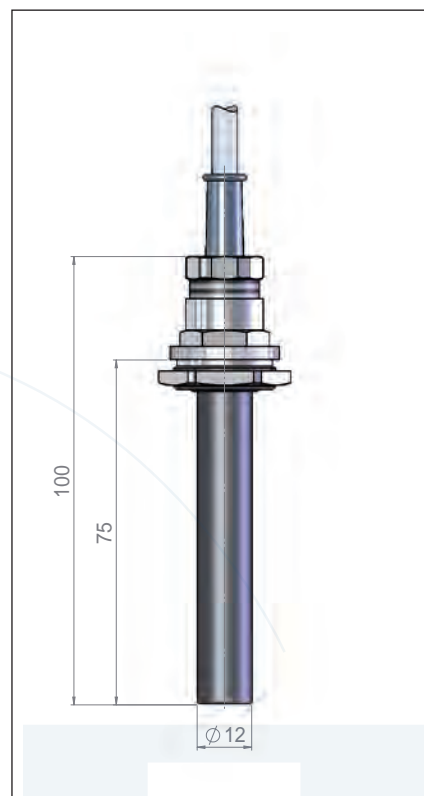

Type **K/PG-16-PA/U/RBI/STB-L75-RU-../PVC**

Material quality:	Polyamide
Electrical connection:	Connection cable
Ambient temperature	
- with PVC connection cable:	-15°C ... +80°C
- with Silicone connection cable:	-15°C ... +80°C
- with PUR connection cable:	-15°C ... +80°C
Installation connection:	PG 16

Switch function:	Change over
Contact material:	Rhodium
Switch behaviour:	Bistable
Switching capacity:	230 V / 0.5 A / 30 VA
Switching capacity ATEX Exia / Exm:	-
Switching frequency:	1000 / sec.
Switching hysteresis:	-

Actuation distances / Magnets page 203	
Actuation:	Front activated

Design pressure:	0 bar ... 0.5 bar
Design temperature:	-15°C ... +80°C
Ingress protection class:	IP 65

Approvals / Certificates:	GL / BV / ABS / SIL1
---------------------------	----------------------

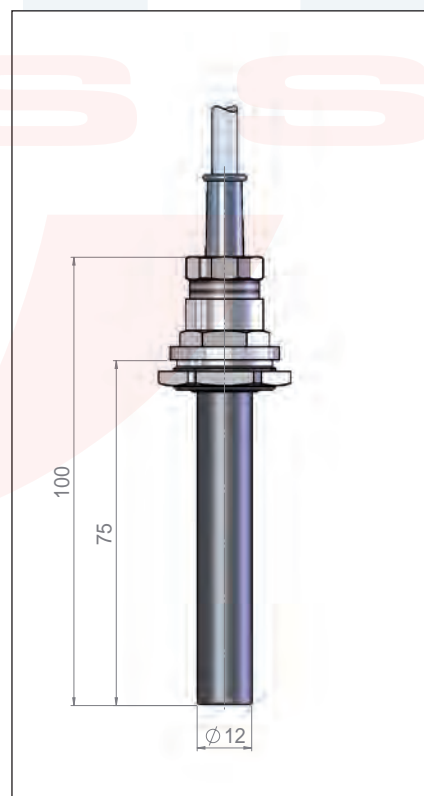

The magnetic switches are based on a modular design and can be conditionally arranged individually.

Type key page 186 - 187

Type **K/LM-18x1.5-PA/S/RMO/STB-L80-RU-.../PVC**

Material quality:	Polyamide
Electrical connection:	Connection cable
Ambient temperature	
- with PVC connection cable:	-15°C ... +80°C
- with Silicone connection cable:	-15°C ... +80°C
- with PUR connection cable:	-15°C ... +80°C
Installation connection:	Thread longitudinal, metric M18 x 1.5 mm
Switch function:	Normally open
Contact material:	Rhodium
Switch behaviour:	Monostable
Switching capacity:	230 V / 1.0 A / 100 VA
Switching capacity ATEX Exia / Exm:	-
Switching frequency:	1000 / sec.
Switching hysteresis:	ca. 5 mm
Actuation distances / Magnets page 203	
Actuation:	Front activated
Design pressure:	0 bar ... 0.5 bar
Design temperature:	-15°C ... +80°C
Ingress protection class:	IP 65
Approvals / Certificates:	GL / BV / ABS / SIL1

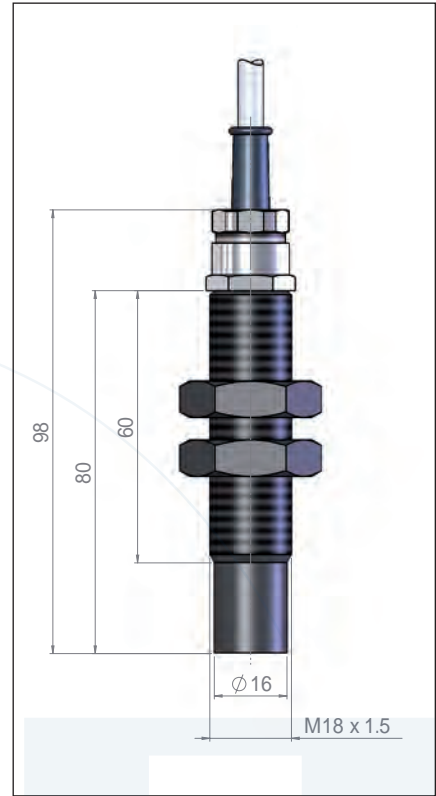

Type **K/LM-18x1.5-PA/U/RMO/STB-L80-RU-.../PVC**

Material quality:	Polyamide
Electrical connection:	Connection cable
Ambient temperature	
- with PVC connection cable:	-15°C ... +80°C
- with Silicone connection cable:	-15°C ... +80°C
- with PUR connection cable:	-15°C ... +80°C
Installation connection:	Thread longitudinal, metric M18 x 1.5 mm
Switch function:	Change over
Contact material:	Rhodium
Switch behaviour:	Monostable
Switching capacity:	230 V / 0.5 A / 30 VA
Switching capacity ATEX Exia / Exm:	-
Switching frequency:	1000 / sec.
Switching hysteresis:	ca. 5 mm
Actuation distances / Magnets page 203	
Actuation:	Front activated
Design pressure:	0 bar ... 0.5 bar
Design temperature:	-15°C ... +80°C
Ingress protection class:	IP 65
Approvals / Certificates:	GL / BV / ABS / SIL1

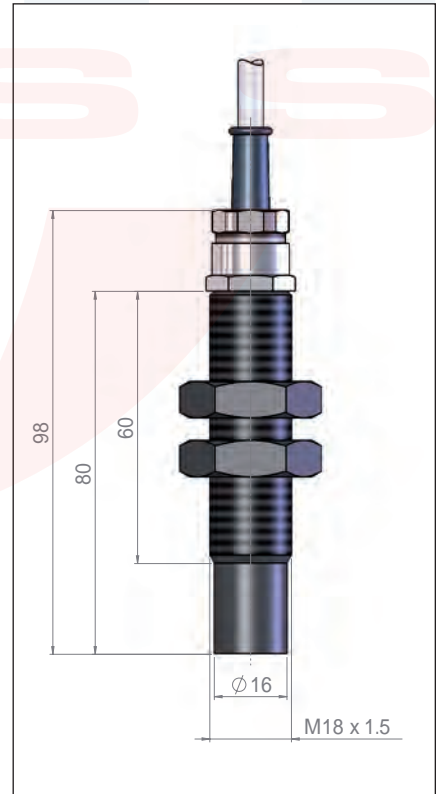

The magnetic switches are based on a modular design and can be conditionally arranged individually.

Type key page 186 - 187

Type **K/LM-18x1.5-PA/U/RBI/STB-L80-RU-../PVC**

Material quality:	Polyamide
Electrical connection:	Connection cable
Ambient temperature	
- with PVC connection cable:	-15°C ... +80°C
- with Silicone connection cable:	-15°C ... +80°C
- with PUR connection cable:	-15°C ... +80°C
Installation connection:	Thread longitudinal, metric M18 x 1.5 mm
Switch function:	Change over
Contact material:	Rhodium
Switch behaviour:	Bistable
Switching capacity:	230V / 0.5A / 30VA
Switching capacity ATEX Exia / Exm:	-
Switching frequency:	1000 / sec.
Switching hysteresis:	-
Actuation distances / Magnets page 203	
Actuation:	Front activated
Design pressure:	0 bar ... 0.5 bar
Design temperature:	-15°C ... +80°C
Ingress protection class:	IP 65
Approvals / Certificates:	GL / BV / ABS / SIL1

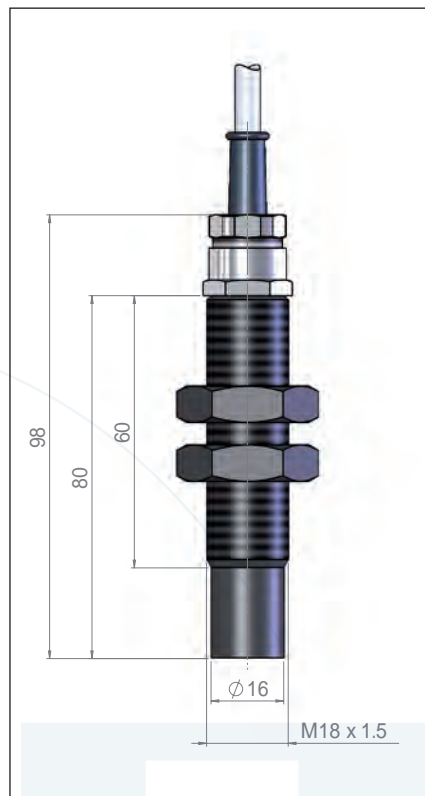

Type **K/OP-PA/S/RMO/SEB-L80-RE-../PVC**

Material quality:	Polyamide
Electrical connection:	Connection cable
Ambient temperature	
- with PVC connection cable:	-15°C ... +80°C
- with Silicone connection cable:	-15°C ... +80°C
- with PUR connection cable:	-15°C ... +80°C
Installation connection:	-
Switch function:	Normally open
Contact material:	Rhodium
Switch behaviour:	Monostable
Switching capacity:	230 V / 1.0 A / 100 VA
Switching capacity ATEX Exia / Exm:	-
Switching frequency:	300 / sec.
Switching hysteresis:	ca. 3 - 4 mm
Actuation distances / Magnets page 203	
Actuation:	Side activated
Design pressure:	0 bar ... 0.5 bar
Design temperature:	-15°C ... +80°C
Ingress protection class:	IP 55
Approvals / Certificates:	GL / BV / ABS / SIL1

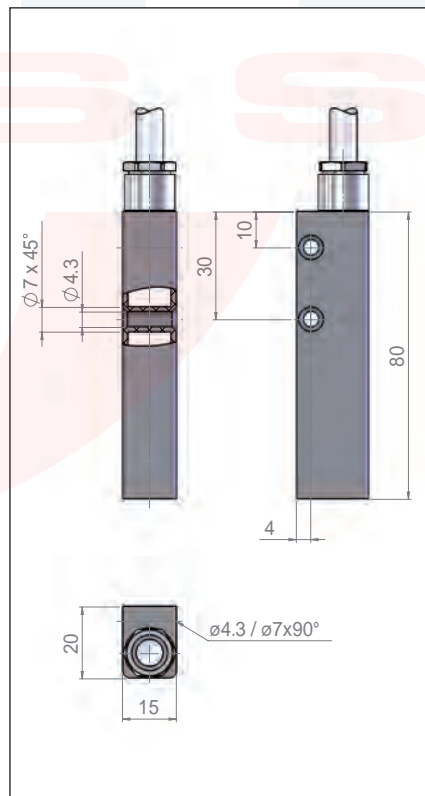

The magnetic switches are based on a modular design and can be conditionally arranged individually.

Type key page 186 - 187

Type **K/OP-PA/S/RMO/STB-L80-RE-../PVC**

Material quality:	Polyamide
Electrical connection:	Connection cable
Ambient temperature	
- with PVC connection cable:	-15°C ... +80°C
- with Silicone connection cable:	-15°C ... +80°C
- with PUR connection cable:	-15°C ... +80°C
Installation connection:	-
Switch function:	Normally open
Contact material:	Rhodium
Switch behaviour:	Monostable
Switching capacity:	230 V / 1.0 A / 100 VA
Switching capacity ATEX Exia / Exm:	-
Switching frequency:	1000 / sec.
Switching hysteresis:	ca. 5 mm
Actuation distances / Magnets page 203	
Actuation:	Front activated
Design pressure:	0 bar ... 0.5 bar
Design temperature:	-15°C ... +80°C
Ingress protection class:	IP 55
Approvals / Certificates:	GL / BV / ABS / SIL1

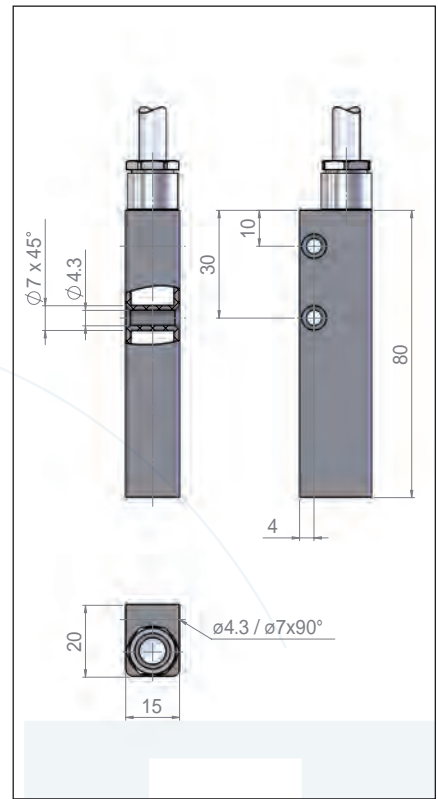

Type **K/OP-PA/U/RMO/STB-L80-RE-../PVC**

Material quality:	Polyamide
Electrical connection:	Connection cable
Ambient temperature	
- with PVC connection cable:	-15°C ... +80°C
- with Silicone connection cable:	-15°C ... +80°C
- with PUR connection cable:	-15°C ... +80°C
Installation connection:	-
Switch function:	Change over
Contact material:	Rhodium
Switch behaviour:	Monostable
Switching capacity:	230 V / 0.5 A / 30 VA
Switching capacity ATEX Exia / Exm:	-
Switching frequency:	1000 / sec.
Switching hysteresis:	ca. 5 mm
Actuation distances / Magnets page 203	
Actuation:	Front activated
Design pressure:	0 bar ... 0.5 bar
Design temperature:	-15°C ... +80°C
Ingress protection class:	IP 55
Approvals / Certificates:	GL / BV / ABS / SIL1

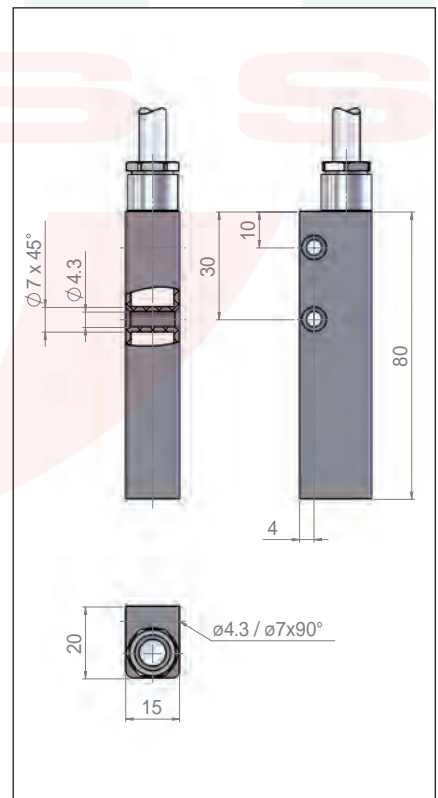

The magnetic switches are based on a modular design and can be conditionally arranged individually.

Type key page 186 - 187

Type **K/OP-PA/S/RBI/STB-L80-RE-.../PVC**

Material quality:	Polyamide
Electrical connection:	Connection cable
Ambient temperature	
- with PVC connection cable:	-15°C ... +80°C
- with Silicone connection cable:	-15°C ... +80°C
- with PUR connection cable:	-15°C ... +80°C
Installation connection:	-

Switch function:	Normally open
Contact material:	Rhodium
Switch behaviour:	Bistable
Switching capacity:	230 V / 1.0 A / 100 VA
Switching capacity ATEX Exia / Exm:	-
Switching frequency:	1000 / sec.
Switching hysteresis:	-

Actuation distances / Magnets page 203	
Actuation:	Front activated

Design pressure:	0 bar ... 0.5 bar
Design temperature:	-15°C ... +80°C
Ingress protection class:	IP 55

Approvals / Certificates:	GL / BV / ABS / SIL1
---------------------------	----------------------

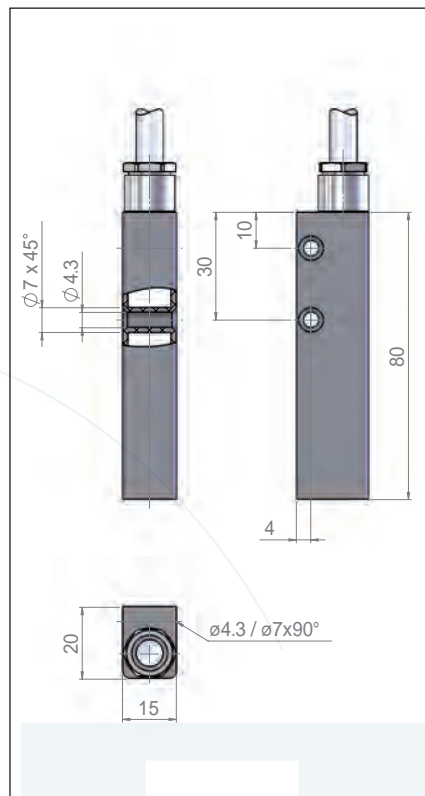

Type **K/OP-PA/U/RBI/STB-L80-RE-.../PVC**

Material quality:	Polyamide
Electrical connection:	Connection cable
Ambient temperature	
- with PVC connection cable:	-15°C ... +80°C
- with Silicone connection cable:	-15°C ... +80°C
- with PUR connection cable:	-15°C ... +80°C
Installation connection:	-

Switch function:	Change over
Contact material:	Rhodium
Switch behaviour:	Bistable
Switching capacity:	230 V / 0.5 A / 30 VA
Switching capacity ATEX Exia / Exm:	-
Switching frequency:	1000 / sec.
Switching hysteresis:	-

Actuation distances / Magnets page 203	
Actuation:	Front activated

Design pressure:	0 bar ... 0.5 bar
Design temperature:	-15°C ... +80°C
Ingress protection class:	IP 55

Approvals / Certificates:	GL / BV / ABS / SIL1
---------------------------	----------------------

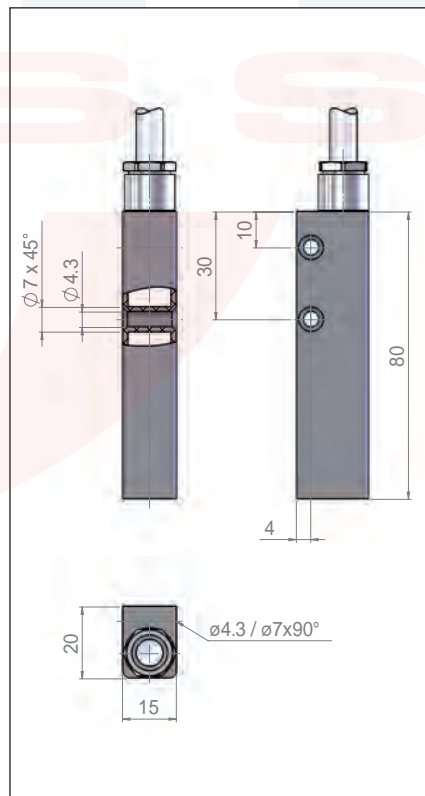

The magnetic switches are based on a modular design and can be conditionally arranged individually.

Type key page 186 - 187

Magnetic Switches / Polyethylene

Type

K/PG-16-PE/S/RMO/STB-L60-RU-../PVC

Material quality:	Polyethylene
Electrical connection:	Connection cable
Ambient temperature	
- with PVC connection cable:	-15°C ... +80°C
- with Silicone connection cable:	-15°C ... +80°C
- with PUR connection cable:	-15°C ... +80°C
Installation connection:	PG 16

Switch function:	Normally open
Contact material:	Rhodium
Switch behaviour:	Monostable
Switching capacity:	230 V / 1.0 A / 100 VA
Switching capacity ATEX Exia / Exm:	100 mA / NAMUR 60 mA
Switching frequency:	300 / sec.
Switching hysteresis:	ca. 5 mm

Actuation distances / Magnets page 203	
Actuation:	Front activated

Design pressure:	0 bar ... 0.5 bar
Design temperature:	-15°C ... +80°C
Ingress protection class:	IP 55

Approvals / Certificates:	ATEX / GL / BV / ABS / SIL1
---------------------------	-----------------------------

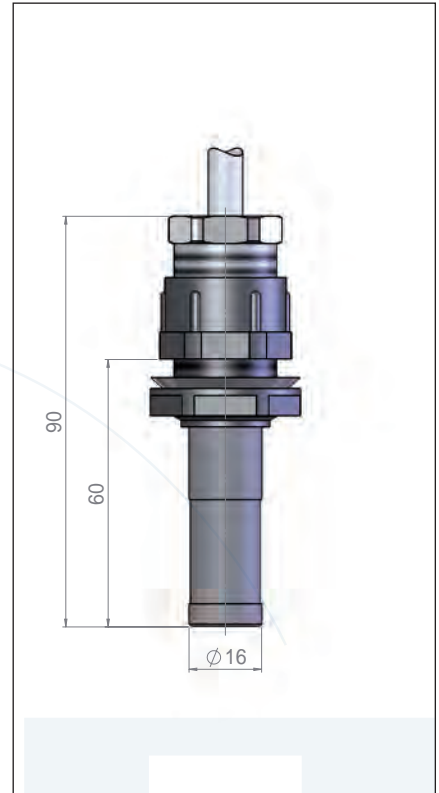

Type

K/PG-16-PE/U/RMO/STB-L60-RU-../PVC

Material quality:	Polyethylene
Electrical connection:	Connection cable
Ambient temperature	
- with PVC connection cable:	-15°C ... +80°C
- with Silicone connection cable:	-15°C ... +80°C
- with PUR connection cable:	-15°C ... +80°C
Installation connection:	PG 16

Switch function:	Change over
Contact material:	Rhodium
Switch behaviour:	Monostable
Switching capacity:	230 V / 0.5 A / 30 VA
Switching capacity ATEX Exia / Exm:	100 mA / NAMUR 60 mA
Switching frequency:	300 / sec.
Switching hysteresis:	ca. 5 mm

Actuation distances / Magnets page 203	
Actuation:	Side activated

Design pressure:	0 bar ... 0.5 bar
Design temperature:	-15°C ... +80°C
Ingress protection class:	IP 55

Approvals / Certificates:	ATEX / GL / BV / ABS / SIL1
---------------------------	-----------------------------

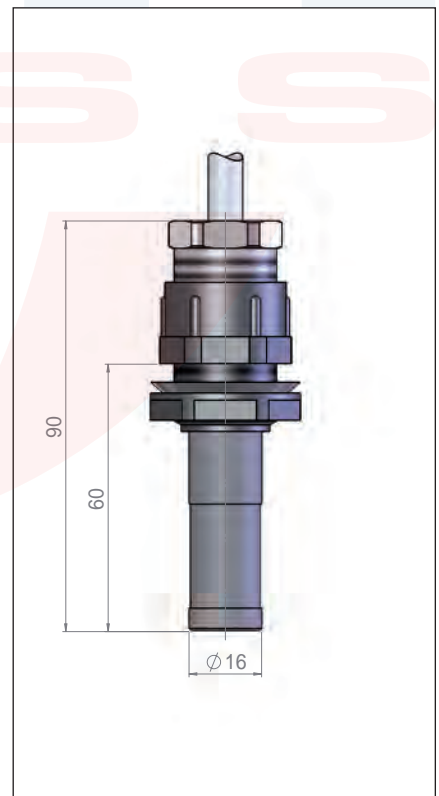

The magnetic switches are based on a modular design and can be conditionally arranged individually.

Type key page 186 - 187

Type

K/PG-16-PE/U/WMO/STB-L60-RU-.../PVC

Material quality:	Polyethylene
Electrical connection:	Connection cable
Ambient temperature:	
- with PVC connection cable:	-15°C ... +80°C
- with Silicone connection cable:	-15°C ... +80°C
- with PUR connection cable:	-15°C ... +80°C
Installation connection:	PG 16
Switch function:	Change over
Contact material:	Wolfram
Switch behaviour:	Monostable
Switching capacity:	230V / 0.5A / 30VA
Switching capacity ATEX Exia / Exm:	100 mA / NAMUR 60 mA
Switching frequency:	100 / sec.
Switching hysteresis:	ca. 1 - 2 mm
Actuation distances / Magnets page 203	
Actuation:	Front activated
Design pressure:	0 bar ... 0.5 bar
Design temperature:	-15°C ... +80°C
Ingress protection class:	IP 55
Approvals / Certificates:	ATEX / GL / BV / ABS / SIL1

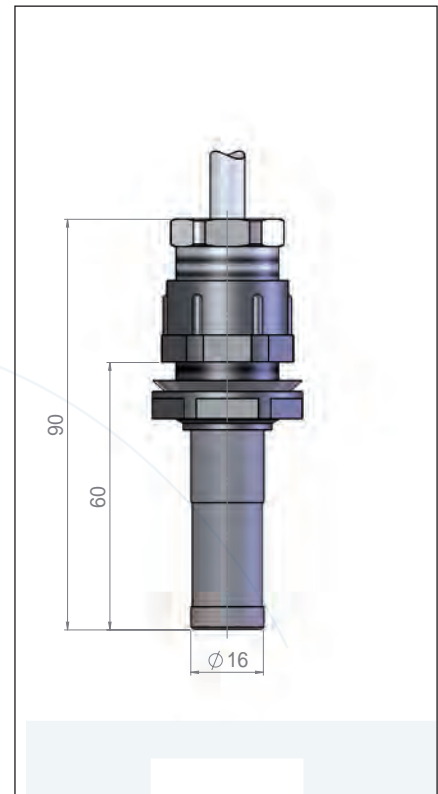

KÜBLER

SWISS

The magnetic switches are based on a modular design and can be conditionally arranged individually.

Type key page 186 - 187

Magnetic Switches / Aluminium

Type

K/OP-AL/S/RMO/STB-L50-RE-../PVC

Material quality:	Aluminium
Electrical connection:	Connection cable
Ambient temperature	
- with PVC connection cable:	-30°C ... +80°C
- with Silicone connection cable:	-30°C ... +180°C
- with PUR connection cable:	-30°C ... +80°C
Installation connection:	-

Switch function:	Normally open
Contact material:	Rhodium
Switch behaviour:	Monostable
Switching capacity:	230 V / 1.0 A / 100 VA
Switching capacity ATEX Exia / Exm:	100 mA / NAMUR 60 mA
Switching frequency:	1000 / sec.
Switching hysteresis:	ca. 5 mm

Actuation distances / Magnets page 203	
Actuation:	Front activated

Design pressure:	0 bar ... 0.5 bar
Design temperature:	-30°C ... +80°C
Ingress protection class:	IP 55

Approvals / Certificates:	ATEX / GL / BV / ABS / SIL1
---------------------------	-----------------------------

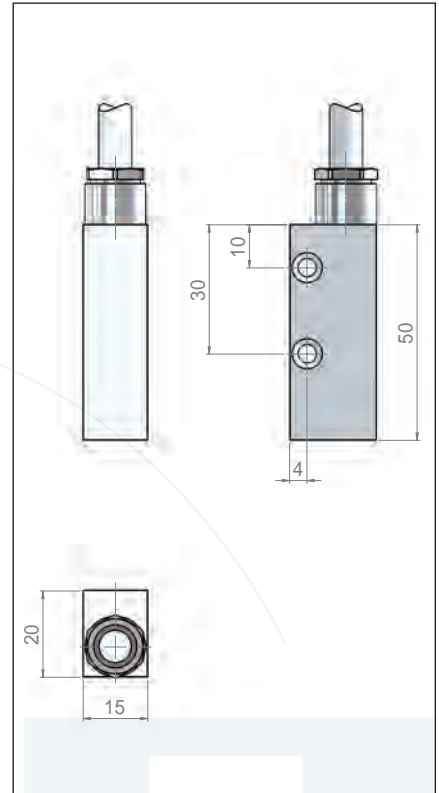

Type

K/OP-AL/S/RBI/STB-L50-RE-../PVC

Material quality:	Aluminium
Electrical connection:	Connection cable
Ambient temperature	
- with PVC connection cable:	-30°C ... +80°C
- with Silicone connection cable:	-30°C ... +180°C
- with PUR connection cable:	-30°C ... +80°C
Installation connection:	-

Switch function:	Change over
Contact material:	Rhodium
Switch behaviour:	Bistable
Switching capacity:	230 V / 1.0 A / 100 VA
Switching capacity ATEX Exia / Exm:	100 mA / NAMUR 60 mA
Switching frequency:	1000 / sec.
Switching hysteresis:	-

Actuation distances / Magnets page 203	
Actuation:	Front activated

Design pressure:	0 bar ... 0.5 bar
Design temperature:	-30°C ... +80°C
Ingress protection class:	IP 55

Approvals / Certificates:	ATEX / GL / BV / ABS / SIL1
---------------------------	-----------------------------

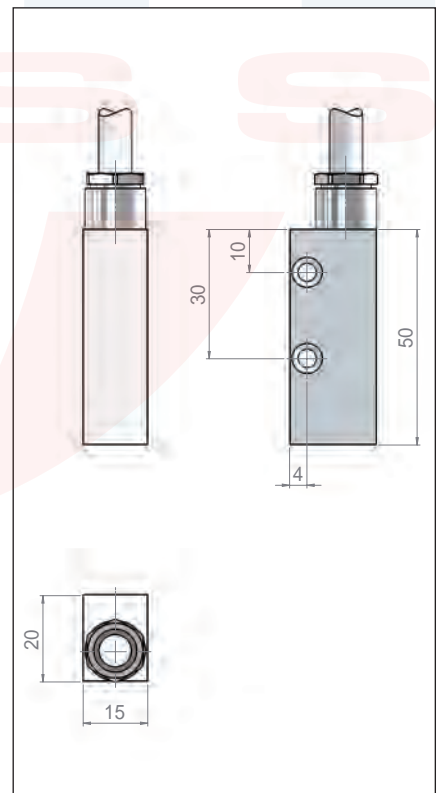

The magnetic switches are based on a modular design and can be conditionally arranged individually.

Type key page 186 - 187

